

INDEX

SECTION B:1

UNIVERSAL JOINT KITS - CENTRE BEARINGS RUBBER DRIVE COUPLINGS - CV JOINTS

DESCRIPTION

SECTION

APPLICATION LISTING

Austin, Chrysler, Daihatsu	B:1-5
Daimler, Fiat, Ford	B:1-6
Great Wall.....	B:1-9
Holden	B:1-10
Hyundai, Jaguar, Jeep, Kia, Lada	B:1-13
Leyland/Morris, Mazda	B:1-14
Mitsubishi.....	B:1-16
Nissan.....	B:1-18
Rover, Subaru.....	B:1-21
Suzuki, Toyota	B:1-22
Triumph, Volvo.....	B:1-26

UNIVERSAL JOINTS

Identification Of Universal Joints	B:1-27
How To Measure Universal Joints	B:1-28
Identification By Part Number.....	B:1-29
Identification By Part Size.....	B:1-33
Circlips.....	B:1-46
Midship Nuts & Torque Specifications	B:1-47
Hardware Torque Specifications.....	B:1-48
Hardware Kits.....	B:1-49
Grease Nipple / Relief Valves.....	B:1-50

CENTRE BEARINGS

Audi, BMW.....	B:1-51
Caterpillar, Chevrolet, Chrysler, Daihatsu.....	B:1-52
Ford	B:1-53
Great Wall, GWB / European.....	B:1-56
Hardy Spicer "D" shape.....	B:1-58
Hino, Holden.....	B:1-60
Honda	B:1-61
Hyundai, Isuzu.....	B:1-62
Iveco	B:1-63
Jaguar, Land Rover	B:1-64
Mack, Man, Maserati.....	B:1-65
Mazda	B:1-66
Mercedes.....	B:1-69

www.hardyspicer.com.au

Document No:	HSDSCAT
Issue:	15
Issue Date:	03/11/14

This catalogue is the copyright
of Hardy Spicer

INDEX

SECTION B:1

UNIVERSAL JOINT KITS - CENTRE BEARINGS RUBBER DRIVE COUPLINGS - CV JOINTS

DESCRIPTION	SECTION
<u>CENTRE BEARINGS cont.</u>	
Mitsubishi.....	B:1-71
Nissan	B:1-72
Porsche, Renault, Scania, Subaru	B:1-74
Ssangyong, Toro.....	B:1-75
Toyota	B:1-76
Volvo	B:1-80
VW	B:1-82
<u>RUBBER DRIVE COUPLINGS</u>	
Audi, BMW, Chrysler	B:1-83
Ford	B:1-84
Holden	B:1-85
Hyundai, Kia, Land Rover.....	B:1-86
Mercedes, Nissan.....	B:1-87
Renault, Skoda, Toyota, VW	B:1-88
<u>PROPELLER SHAFT CV JOINTS</u>	
BMW, Ford	B:1-89
Holden, Honda	B:1-91
Hyundai, Jeep	B:1-92
Kia, Landrover, Mazda, Mitsubishi	B:1-93
Nissan, Porsche, Toyota.....	B:1-94
VW, Volvo	B:1-95

www.hardyspicer.com.au

Document No:	HSDSCAT
Issue:	15
Issue Date:	03/11/14

This catalogue is the copyright
of Hardy Spicer

DISCLAIMER & WARRANTY

Disclaimer

The information and dimensions listed in these catalogues is correct to the best of our knowledge and belief, having been compiled from reliable and official sources of information. However Hardy Spicer (HS Company Pty Ltd) accepts no responsibility for possible errors, omissions or unsuitable parts being listed or fitted to any vehicle. Dimensions listed are nominal throughout. Due to our continuous product and range development we reserve the right to alter the specification without prior notice.

We welcome any feedback re suspected errors or omissions to the information enclosed. We can be contacted via email hspicer@hardyspicer.com.au
Or via Ph 03 9794 1900 or Fax 03 97069928
Alternatively via mail at PO Box 4262, Dandenong South, Vic. 3164.

Warranty is designed to protect you from unforeseen defects in manufacturing materials and workmanship. It is not a guarantee that the product will not fail when the product is used in a manner outside the design parameters of the goods.

Warranty Policy - Universal Joint Driveshafts and Components (Also please refer Terms and Conditions on rear of Invoice)

Hardy Spicer (HS Company Pty Ltd) warrants to the original purchaser that Universal Joints, Driveshaft Components and Driveshaft assemblies purchased from the Company will be free of defects in materials and workmanship subject to the following conditions.

The period of warranty will be for

- Passenger Vehicles (used exclusively on formed roads) 12 months or 20,000 km's whichever occurs first.
- Commercial or Off Road vehicles 3 months or 250 hours whichever occurs first.
- Industrial and Agricultural - 3 months or 250 hours whichever comes first.

Claims for replacement of parts will only be processed after inspection and acceptance by the Company and/or its supplier that product is defective in materials or workmanship. These items should be returned freight pre-paid by the purchaser after contacting the company for return instructions, with proof of purchase and documentation stating the reason for the warranty claim.

This Warranty is subject to the following limitations:

- Damage caused by improper installation, negligence, misuse, failure to follow our instructions or recommendations, or alterations or repair of goods without our approval.
- "Staked Replacement" joints are excluded due to torque capacity limitations of this replacement design. These should be used as an Emergency repair only. Hardy Spicer sell a range of replacement components rated to match or exceed the original staked joint designs and we strongly recommend their use in replacing unserviceable staked joints.
- Any product used in vehicles subject to Racing competition of any form, Speed Trials, Performance Dyno testing or vehicles that have been modified from the Manufacturer's original specifications are excluded except for dimensional defects.
- Any Driveshaft or Universal Joint component directly coupled to an internal combustion engine without a torsionally resilient coupling will be excluded from any claim.

Liability under this warranty is limited to the replacement of the component supplied if accepted by the Company to be defective in materials or workmanship. No liability is accepted for any consequential damage, transport, removal, installation, towing including loss of profits or other economic loss.

www.hardyspicer.com.au

Document No:	HSDSCAT
Issue:	15
Issue Date:	03/11/14

This catalogue is the copyright
of Hardy Spicer

Warranty Policy - CV Driveshafts and Components (Also please refer Terms and Conditions on rear of Invoice)

Hardy Spicer (HS Company Pty Ltd) warrants to the original purchaser that CV Joints, CV Driveshaft Components and CV Driveshaft assemblies purchased from the Company will be free of defects in materials and workmanship subject to the following conditions.

The period of warranty will be for

- a. Complete CV Shafts - 2WD (used exclusively on formed roads) is 2 years or 40,000 km's whichever occurs first.
- b. Complete CV Shafts - 4WD is 1 year or 20,000 km's whichever occurs first.
- c. CV Joints 1 year or 20,000 km's whichever occurs first. Correct grease and CV boot must be used to allow warranty to be approved.
- d. CV Boots 6 months or 10,000km's whichever occurs first.
- e. CV Shafts and Joints used in commercial and taxi operations - 3 months.

Claims for replacement of parts will only be processed after inspection and acceptance by the Company and/or its supplier that product is defective in materials or workmanship. These items should be returned freight pre-paid by the purchaser after contacting the company for return instructions with proof of purchase and documentation stating the reason for the warranty claim.

This Warranty is subject to the following limitations:

- a. Damage caused by improper installation, negligence, misuse, failure to follow our instructions or recommendations, or alterations or repair of goods without our approval.
- b. Any product used in vehicles subject to Racing competition of any form, Speed Trials, Performance Dyno testing or vehicles that have been modified from the Manufacturer's original specifications are excluded except for dimensional defects.
- c. Any CV Shaft or CV Joints used in mining applications are excluded from any claim.

Liability under this warranty is limited to the replacement of the component supplied if accepted by the Company to be defective in materials or workmanship. No liability is accepted for any consequential damage, transport, removal, installation, towing including loss of profits or other economic loss.

www.hardyspicer.com.au

Document No:	HSDSCAT
Issue:	15
Issue Date:	03/11/14

This catalogue is the copyright of Hardy Spicer

Document No:	HSDSCAT
Issue:	15
Issue Date:	03/11/14

APPLICATION LISTING



Make	Year	Joint Position			Notes	
		Front	Middle	Rear		
AUSTIN						
1800	MANUAL	65-70	K5-A514		N/A	INNER HALF SHAFT
	AUTO	65-70	K5-L4R		N/A	INNER HALF SHAFT
TASMAN, KIMBERLEY		70-73	K5-A514		N/A	INNER HALF SHAFT
CHRYSLER						
GENTURA	KB, KC	75-78	RUJ-2038R		RUJ-2038R	6 CYL
VALIANT	AP5, AP6, VC MANUAL	62-69	114-67R		RUJ-2038R	
	VC(AUTO), VE - CM	66-78	RUJ-2038R		RUJ-2038R	EXC CHARGER D74
	VJ, VK CHARGER	73-76	RUJ-2038R		114-232	D74 & H/D AXLE(SURE GRIP)
DAIHATSU						
HI JET	S38,40,60,65,70	72-84	K5-A510		K5-A510	
	S75,85	84-90	RUJ-1500		RUJ-1500	
	S76 4WD	84-86	K5-A510		K5-A510	FRONT SHAFT
	S76 4WD	84-86	RUJ-1500		RUJ-1500	REAR SHAFT
DELTA	ALL	73-77	K5-A522		K5-A522	EXC SOME 3.0L MODELS(RUJ-2505)
	ALL	77-8/84	RUJ-2505	RUJ-2505	RUJ-2505	
F SERIES	F10	74-3/75	K5-A522		K5-A522	
	ALL F SERIES & SCAT	4/75-85	RUJ-2023		RUJ-2023	
FEROZA 4WD	F300,F310	10/88-1/99	RUJ-1500		RUJ-1500	FRONT SHAFT
	F300,F310	10/88-1/99	K5-A522		K5-A522	REAR SHAFT
ROCKY 4WD	ALL MODELS	84-93	RUJ-2023		RUJ-2023	FRONT & REAR SHAFT (INT SNAP RING TYPE)SOME
			K5-A522		K5-A522	FRONT & REAR SHAFT (EXT CIRCLIP TYPE) MOST
	F78 SPORTS WAGON	9/93-1/99	K5-A522		K5-A522	FRONT & REAR SHAFT
TERIOS 4WD	J100/J102 DX/SX WAGON	97 ON	RUJ-1500		RUJ-1500	FRONT & REAR SHAFT

Document No:	HSDSCAT
Issue:	15
Issue Date:	03/11/14

APPLICATION LISTING



Make	Year	Joint Position			Notes	
		Front	Middle	Rear		
DAIMLER						
DOUBLE SIX	SERES 1,2,3	72-	K5-13XR	K5-13XR	K5-13XR	DRIVE SHAFT
			K5-GB10R		K5-GB10R	HALF SHAFT
SOVEREIGN	SERIES 1,2,3	68-86	K5-13XR	K5-13XR	K5-13XR	DRIVE SHAFT
			K5-GB10R		K5-GB10R	HALF SHAFT
		86ON	K5-A757	K5-A757	K5-A757	DRIVE SHAFT
FIAT						
124,125,131,132		68-82	K5-LGB80R		K5-LGB80R	
130		72-76	K5-L4R		K5-L4R	
FORD						
CAPRI	4 CYL IMPORTED PROD	69-73	K5-GB150	K5-GB150	K5-GB150	EXTERNAL CIRCLIP TYPE
	4 CYL AUST BUILT	71-73	RUJ-1786R	RUJ-1786R	RUJ-1786R	INTERNAL SNAP RING TYPE
	V6 IMPORTED	69-	K5-A655		K5-A655	STAKED JOINT (UNSERVICEABLE WITHOUT SPECIAL TOOLING) REFER HARDY SPICER
	V6 AUST BUILT	71-	RUJ-1786R	RUJ-1786R	RUJ-1786R	INTERNAL SNAP RING TYPE
CORTINA	MK 1, 2	62-71	K5-GB150		K5-GB150	EXTERNAL CIRCLIP TYPE
	MK 1, 2	62-71	K5-A650		K5-A650	STAKED JOINT (UNSERVICEABLE WITHOUT SPECIAL TOOLING) REFER HARDY SPICER
	MK 1, 2 AUST BUILT	69-71	RUJ-1786R		RUJ-1786R	INTERNAL SNAP RING TYPE
	TC,TD,TE,TF 4 CYL ALL	71-82	RUJ-1786R	RUJ-1786R	RUJ-1786R	
	TC,TD,TE,TF 6 CYL ALL	71-82	RUJ-2038R		RUJ-2038R	
ESCORT	MK1 1100,1300,1558 T/CAM	66-3/70	K5-GB150		K5-GB150	
	MK 1 1100	4/70 ON	RUJ-1786R		RUJ-1786R	
	MK 1 1300	4/70-75	RUJ-1786R	RUJ-1786R	RUJ-1786R	
	MK 1, 2 SOME	66-81	K5-A650		K5-A650	STAKED JOINT (UNSERVICEABLE WITHOUT SPECIAL TOOLING) REFER HARDY SPICER
	MK 2 1300,1600,2000	75-81	RUJ-1786R	*RUJ-1786R	RUJ-1786R	1 AND *2 PIECE SHAFTS
FAIRLANE (6 CYL)	ZA,ZB	67-69	K5-13XR		RUJ-2039	
	ZC	69-70	RUJ-2038R		RUJ-2029	
	ZD-NA	71-5/91	RUJ-2038R		RUJ-2038R	
	NC	6/91-95	RUJ-2038R		RUJ-2038R	STEEL SHAFTS
	NC-AU	6/91-02	K5-13XR		K5-13XR	ALUMINIUM SHAFTS

Document No:	HSDSCAT
Issue:	15
Issue Date:	03/11/14

APPLICATION LISTING



Make	Year	Joint Position			Notes
		Front	Middle	Rear	
FORD cont.					
FAIRLANE (V8)	ZA, ZB	67-69	K5-13XR		RUJ-2039
	ZC 302 3SPD MAN	69-70	RUJ-2038R		RUJ-2029
	ZC, ZD, ZF, ZG 351 FMX AUTO	69-76	K5-13XR		RUJ-2039
	ZD, ZF, ZG 302	70-76	RUJ-2038R		RUJ-2038R
	ZH 4.9L	76-79	RUJ-2038R		RUJ-2038R
	ZH 5.8L	76-79	RUJ-2038R		RUJ-2029
	ZH 5.8L	76-79	K5-13XR		RUJ-2039
	ZJ, ZK	79-84	RUJ-2038R		RUJ-2038R
	NC	6-91-95	RUJ-2038R		RUJ-2038R
	NC-AU	6/91-02	K5-13XR		K5-13XR
FALCON (6 CYL)	XK-XR	60-67	RUJ-1786R		RUJ-1786R
	XR, XT (TAXI H/D MODEL)	67-68	K5-13XR		RUJ-2039
	XT, XW 188 CU. IN	68-69	RUJ-1786R		RUJ-1786R
	XW	69-70	RUJ-2038R		RUJ-2029
	XY-XC WITH DRUM BRAKES	70-79	RUJ-2038R		RUJ-2038R
	XC WITH DISC REAR BRAKES	76-79	RUJ-2038R		RUJ-2029
	XD, XE, XF	79-88	RUJ-2038R		RUJ-2038R
	XG UTE, VAN	93-96	K5-13XR		K5-A530
	XG -XH UTE, VAN	93-99	K5-13XR		K5-13XR
	EA MAN & 3SPD AUTO	88-6/91	RUJ-2038R		RUJ-2038R
	EA AUTO SED & MPFI WAGON	88-6/91	K5-13XR		K5-13XR
	EA WAGON 4SPD AUTO TBFI	88-6/91	K5-13XR		K5-A530
	EB, ED, EF, EL AU, AU2, AU3	7/91-10/02	K5-13XR		K5-13XR
	BA SEDAN ALL 6 CYL (EXCEPT TURBO)	11/02 ON	*GAJ-1-0	K5-13XR	CV-860
	BA MKII, BF SEDAN ALL 6 CYL (EXCEPT TURBO)	10/04 ON	*GAG03-001-0	K5-13XR	CV-860
	BA, BF SEDAN 6CYL TURBO WITH CENTRE UJOINT	11/02 ON	*GAG03-001-0	K5-13XR	CV-860
	BA, BF SEDAN 6CYL TURBO WITHOUT UJOINT	11/02 ON	*GAG03-001-0	CV-862	CV-861
	BA, BF 6 CYL ALL INCL TURBO, WAGON, UTE	11/02 ON	K5-13XR		K5-13XR
FALCON (V8)	XR, XT, XW INC GT	66-69	K5-13XR		RUJ-2039
	XW, XY GTHO	69-71	RUJ-3002		RUJ-3000
	XY, XA, XB 302	70-76	RUJ-2038R		RUJ-2038R
	XA, XB 302	72-76	RUJ-2038R		RUJ-2029
	XA, XB 351 INC GT	72-76	K5-13XR		RUJ-2039
	XA, XB 351GT WITH H/D SHAFT	72-76	RUJ-3002		RUJ-3000
	XC SEDAN	76-79	RUJ-2038R		RUJ-2038R
	XC SEDAN	76-79	RUJ-2038R		RUJ-2029
	XC 351 WAGON, UTE, VAN	76-79	K5-13XR		RUJ-2039
	XD, XE,	79-84	RUJ-2038R		RUJ-2038R
	EB	7/91-93	RUJ-2038R		RUJ-2038R

Document No:	HSDSCAT
Issue:	15
Issue Date:	03/11/14

APPLICATION LISTING



Make	Year	Joint Position			Notes	
		Front	Middle	Rear		
FORD cont.						
FALCON (V8) cont.	EB,ED,EF,EL,AU,AU2,AU3	7/91-10/02	K5-13XR		K5-13XR	
	BA,BF V8 SEDAN WITH CENTRE U/JOINT	11/02 ON	*GAG03-001-0	K5-13XR	CV-860	* RUBBER COUPLING FRONT BF SERIES II HAS GAD03-001-0
	BA,BF V8 SEDAN WITH CENTRE CV JOINT	11/02 ON	*GAG03-001-0	CV-862	CV-861	* RUBBER COUPLING FRONT BF SERIES II HAS GAD03-001-0
	BA,BF V8 WAGON, UTE ALL	11/02 ON	K5-13XR		K5-13XR	
LTD	P5 LTD /LANDAU	73-76	K5-13XR		RUJ-2039	
	P6 LTD	76/79	RUJ-2038R		RUJ-2029	
	FC,FD,FE	5/79-5/88	RUJ-2038R		RUJ-2038R	
	DC, DF(SOME)	6/88-7/91	RUJ-2038R		RUJ-2038R	STEEL TAILSHAFT INTERNAL SNAP RINGS
	DF,DL,AU	8/91-03	K5-13XR		K5-13XR	ALUMINIUM TAILSHAFT AND/OR EXTERNAL SNAP RINGS
BRONCO, F100, F150	ALL					
F250, F350NOTE: RANGE OF JOINTS USED REQUIRES THAT ALL APPLICATIONS SHOULD BE MEASURED TO ENSURE CORRECT FITMENT OF EACH JOINT						
COURIER	2WD VC,MA, 2.0L, 2.2L	78-98	RUJ-2023	RUJ-2023	RUJ-2023	SOME VEHICLES HAVE STAKED JOINTS (UNSERVICEABLE WITHOUT SPECIAL TOOLING)REFER HARDY SPICER
	PE, PG, 2.6L & 2.5DT	02/99-8/04	K5-13XR	K5-13XR	K5-13XR	
	PH, 2.6L & 2.5DT	9/04-10/06	RUJ-3002	RUJ-3002	RUJ-3002	
	4X4, PC, PD	87-98	RUJ-2049		RUJ-2049	FRONT SHAFT
		87-98	RUJ-2023	RUJ-2023	RUJ-2023	REAR SHAFT
	4X4, PE, PG	99-8/04	RUJ-2049		RUJ-2049	FRONT SHAFT
		99-8/04	K5-13XR	K5-13XR	K5-13XR	REAR SHAFT
						SOME VEHICLES HAVE STAKED JOINTS (UNSERVICEABLE WITHOUT SPECIAL TOOLING)REFER HARDY SPICER
	4X4, PH, 2.6L & 2.5DT	9/04-10/06	K5-13XR		K5-13XR	FRONT SHAFT
		9/04-10/06	K5-13XR	K5-13XR	K5-13XR	REAR SHAFT
	4X4, 4.0L	9/04-10/06	K5-13XR		CV JOINT	FRONT SHAFT (CV JOINT NOT CURRENTLY SERVICEABLE)
		09/04-10/06	CV JOINT	CV JOINT	CV JOINT	REAR SHAFT (FITTED WITH THREE CV JOINTS - NOT CURRENTLY SERVICEABLE)
ECONOVAN(SPECTRON)	EASYLOADER	79-88	RUJ-1784		RUJ-1784	DUAL REAR WHEELS
		83 ON	RUJ-2049		RUJ-2049	SINGLE REAR WHEELS
						SOME VEHICLES HAVE STAKED JOINTS (UNSERVICEABLE WITHOUT SPECIAL TOOLING)REFER HARDY SPICER
	MAXI	85 ON	RUJ-2023		RUJ-2023	
	SPECTRON 4X4	85-88	RUJ-2049		RUJ-2049	FRONT SHAFT
	SPECTRON 4X4	85-88	RUJ-2023		RUJ-2023	REAR SHAFT
EXPLORER	4X4 WAGON	96 ON	K5-13XR		K5-13XR	FRONT SHAFT W/ SPORT TRAC
		96 ON	RUJ-3002		RUJ-3002	REAR SHAFT
		02 ON	K5-13XR		CV-860	FRONT SHAFT

Document No:	HSDSCAT
Issue:	15
Issue Date:	03/11/14

APPLICATION LISTING



Make	Year	Joint Position			Notes
		Front	Middle	Rear	
FORD cont.					
RAIDER	4X4	91 ON	RUJ-2049	RUJ-2049	FRONT SHAFT
		91 ON	RUJ-2023	RUJ-2023	REAR SHAFT
RANGER	2WD, PJ 2.5DT	11/06 ON	5-618XD	5-618XD	(HD LUBE IN CAP OPTION AVAILABLE ALSO Part # 5-618-1XD)
	4WD, PJ 3.0DT	11/06 ON	K5-13XR	K5-13XR	FRONT SHAFT
		11/06 ON	5-618XD	5-618XD	REAR SHAFT (HD LUBE IN CAP OPTION AVAILABLE ALSO Part # 5-618-1XD)
TRANSIT	V21, V22, V24, V33 4CYL MAN	65-74	K5-L4R	K5-L4R	
	V21, V22, V24, V33, V51, V54, V65 4CYL AUTO	68-74	K5-13XR	K5-13XR	
	V51, V54, V65 4CYL MAN	65-74	K5-13XR	K5-13XR	
	V21, V23, V33, V51(AUST PROD)	78 -82	RUJ-2038R	RUJ-2038R	
TRANSIT (CONT.)	V24, V51, V54(AUST PROD) LWB	78-82	RUJ-2030R	RUJ-2030R	SINGLE & DUAL REAR WHEELS
	NEW TRANSITS	94 ON		CV-856	(SOME) 94MM DIAMETER CV JOINT(BOOT KIT INCLUDED)
		94 ON		CV-288	(SOME) 108MM DIAMETER CV JOINT (BOOT KIT TO SUIT NL-5-15)
		01 ON	*GAF01-003-0		(SOME) *RUBBER COUPLING FRONT
MANY DRIVESHAFT CONFIGURATIONS VARIANTS					
ALL VEHICLES HAVE STAKED JOINTS (UNSERVICEABLE WITHOUT SPECIAL TOOLING) REFER HARDY SPICER SHAFT REPLACEMENT OPTIONS					
MAVERICK	DA 4X4	87-92	RUJ-2028	RUJ-2028	FRONT SHAFT
		87-92	RUJ-3007	RUJ-3007	REAR SHAFT
GREAT WALL					
V200	2.0L 2WD	8/2011-	K5-A842	K5-A842	K5-A842
	2.0L 4WD	8/2011-	K5-A843		K5-A843
			K5-A842	K5-A842	K5-A842
					FRONT SHAFT
					REAR SHAFT
V240	2.4L 2WD	6/2009-	K5-A842	K5-A842	K5-A842
	2.4L 4WD	6/2009-	K5-A843		K5-A843
			K5-A842	K5-A842	K5-A842
					FRONT SHAFT
					REAR SHAFT
X200	2.0L 4WD AUTO	1/2012-	K5-A842		K5-A842
	2.0L 4WD MAN	10/2011-	K5-A757		K5-A757
			K5-A842		K5-A842
					FRONT AND REAR SHAFTS
					FRONT SHAFT
					REAR SHAFT
X240	2.4L 4WD	10/2009-	K5-A842		K5-A842
					FRONT AND REAR SHAFTS

Document No:	HSDSCAT
Issue:	15
Issue Date:	03/11/14

APPLICATION LISTING



Make	Year	Joint Position			Notes
		Front	Middle	Rear	
HOLDEN					
EARLY MODELS(6 CYL)	FX-FJ	48-56	RUJ-1786R		RUJ-1764
	FB,FC,FE,EK,EJ	56-63	RUJ-1786R		RUJ-1758
	EH,HD,HR,	63-67	RUJ-1786R		RUJ-1786R
	HK (SEE NOTES)	68-69	RUJ-1786R		RUJ-2030R
	HK,HT,HG,HQ,HJ,HX,HZ	68-80	RUJ-1786R		RUJ-1786R
	HJ,HX,HZ	74-80	RUJ-2030R		RUJ-2030R
	WB	80-85	RUJ-2030R		RUJ-2030R
	HQ ONE TONNER (SOME)	71-73	RUJ-2030R		RUJ-2030R
	HQ-WB ONE TONNER	71-85	RUJ-2500R		RUJ-2500R
EARLY MODELS (V8)	HK 307	68-69	RUJ-1786R		RUJ-1786R
	HK, HT 307	68-70	RUJ-2030R		RUJ-2030R
	HK, HT 307	68-70	RUJ-2030R		RUJ-2032
	HT, HG 253	69-71	RUJ-2030R		RUJ-2030R
	HT 308	69-70	RUJ-2500R		RUJ-2502
	HG 308	70-71	RUJ-2030R		RUJ-2030
					RUJ-2032
	HG 350	70-71	RUJ-2500R		RUJ-2502
	HG 350	70-71	RUJ-2030R		RUJ-2032
	HQ 253,308	71-74	RUJ-2030R		RUJ-2030R
	HQ 350	71-74	RUJ-2500R		RUJ-2500R
	HJ,HX,HZ 253 & 308	74-80	RUJ-2030R		RUJ-2030R
					253 ALL ,308 MAN & AUTO EXCEPT TURBO 400
EARLY MODELS (V8) cont.	HJ, HX HZ 308	74-80	RUJ-2500R		RUJ-2030R
	WB EXCEPT ONE TONNER	80-85	RUJ-2030R		RUJ-2030R
	HQ-WB ONE TONNER	71-85	RUJ-2500R		RUJ-2500R
COMMODORE (4 CYL)	VC, VH	80-83	RUJ-1786R	CV-856	RUJ-1786R
COMMODORE (6 CYL)	VB, VC,VH	78-84	RUJ-1786R	CV-856	RUJ-1786R
	VB,VC,VH	78-84	RUJ-2030R	CV-855A	RUJ-2030R
	VK	84-86	RUJ-1786R	CV-856	RUJ-1786R
	VK EFI, VL	84-88	RUJ-2030R	CV-855A	RUJ-2030R
	VN,VP,VR,VS & VT AUTO	88-98	RUJ-2038R	CV-855A	RUJ-2038R
	VT MAN	96-9/00	RCA-1059	CV-855A	RUJ-2038R
	VX,VY,VZ,VE MAN	10/00 ON	RCA-1060	STAKED	RCA-1061
	VX,VY,VZ,VE AUTO	10/00 ON	RCA-1060	STAKED	RCA-1060
	VX,VY,VZ AUTO SUPERCHARGED V6	10/00 ON	RCA-1061	STAKED	RCA-1061
ALL VX, VY, VZ, VE'S HAVE STAKED MIDDLE JOINTS (UNSERVICEABLE WITHOUT SPECIAL TOOLING)REFER HARDY SPICER SHAFT REPLACEMENT OPTIONS					

Document No:	HSDSCAT
Issue:	15
Issue Date:	03/11/14

APPLICATION LISTING



Make	Year	Joint Position			Notes	
		Front	Middle	Rear		
HOLDEN cont.						
COMMODORE (V8)	VB, VC, VH,	78-84	RUJ-2030R	CV-855A	RUJ-2030R	253 ALL, 308 MAN AND AUTO EXCEPT TURBO 400
	VB, VC, VH 308 TURBO 400 ONLY	78-84	RUJ-2500R	CV-855A	RUJ-2030R	
	VK, VL	84-88	RUJ-2030R	CV-855A	RUJ-2030R	
	VP, VR, VS & VT AUTO	88-9/00	RUJ-2038R	CV-855A	RUJ-2038R	
	VT SERIES 1 V8 MANUAL	9/97-9/00	RCA-1058	CV-855A	RUJ-2038R	FRONT HAS RUBBER DRIVE COUPLING(DONUT)
	VT SERIES 2 5.7L GEN 3 (HI PERF)MAN	98-9/00	10005422	CV-855A	RUJ-2038R	FRONT HAS RUBBER DRIVE COUPLING(DONUT)
	VX, VY, VZ	10/00 ON	RCA-1061	STAKED	RCA-1061	FRONT & REAR RUBBER DRIVE COUPLINGS
	VE	10/06 ON	RCA-1062	STAKED	RCA-1062	FRONT & REAR RUBBER DRIVE COUPLINGS
ALL VX, VY, VZ, VE'S HAVE STAKED MIDDLE JOINTS (UNSERVICABLE WITHOUT SPECIAL TOOLING)REFER HARDY SPICER SHAFT REPLACEMENT OPTIONS						
DROVER	QG	85-87	RUJ-1795		RUJ-1795	IF INTERNAL SNAP RINGS
	QG	85-87	K5-A556		K5-A556	IF EXTERNAL CIRCLIPS
FRONTERA	2.0L 2 DOOR	96 ON	K5-L4R		K5-L4R	FRONT & REAR SHAFTS
GEMINI	TC, TD, TE, TF, TG, TX PETROL	75 -	RUJ-1786		RUJ-1786	DIESEL GEMINIS HAVE STAKED JOINTS (UNSERVICABLE WITHOUT SPECIAL TOOLING)REFER HARDY SPICER SHAFT REPLACEMENT OPTIONS
JACKEROO	UBS	81-7/88	K5-LGB80R		RUJ-2033	FRONT SHAFT
			RUJ-2033	RUJ-2033	RUJ-2033	REAR SHAFT
				(LWB ONLY)		
	UBS	8/88-5/98	RUJ-2033		RUJ-2033	FRONT SHAFT
		8/88-5/98	RUJ-2033	RUJ-2033	RUJ-2033	REAR SHAFT
				(LWB ONLY)		
	UVS 3.5L V6 AND TURBO DIESEL	6/98 ON	RUJ-3011		RUJ-3011	FRONT SHAFT
			RUJ-3011	RUJ-3011	RUJ-3011	REAR SHAFT
	UVS MONTEREY(WITH TORQUE DEMAND ONLY)	6/98 ON	RUJ-2033		RUJ-2033	FRONT SHAFT
			RUJ-2033	RUJ-2033	RUJ-2033	REAR SHAFT
PIAZZA	2.0L TURBO	86-88	STAKED		STAKED	THESE VEHICLES HAVE STAKED JOINTS (UNSERVICABLE WITHOUT SPECIAL TOOLING)REFER HARDY SPICER SHAFT REPLACEMENT OPTIONS
RODEO 2WD	KB, KBD 20 SERIES	75-88	K5-LGB80R	K5-LGB80R	K5-LGB80R	
	TF SERIES	8/88 ON	RUJ-2036	RUJ-2036	RUJ-2036	
	TF R9 3.2 V6	6/98 2003	RUJ-3011	RUJ-2036	RUJ-2036	

Document No:	HSDSCAT
Issue:	15
Issue Date:	03/11/14

APPLICATION LISTING



Make	Year	Joint Position			Notes	
		Front	Middle	Rear		
HOLDEN cont.						
RODEO 4WD	KB, KBD 20 SERIES	79-7/88	K5-LGB80R		RUJ-2033	FRONT SHAFT
		79-7/88	RUJ-2033		RUJ-2033	REAR SHAFT
	TF SERIES	8/88 ON	RUJ-2033		RUJ-2033	FRONT SHAFT - RUJ-2036 NON LUBE USED IN SOME VEHICLES
		8/88 ON	RUJ-2033	RUJ-2033	RUJ-2033	REAR SHAFT - RUJ-2036 NON LUBE USED IN SOME VEHICLES
	TF R9 3.2 V6, TURBO DIESEL	6/98 -2003	RUJ-2036		RUJ-2036	FRONT SHAFT
		6/98 -2003	RUJ-3011	RUJ-2036	RUJ-2036	REAR SHAFT
	RA TURBO DIESEL	2003 -	RUJ-2036		RUJ-2036	FRONT SHAFT
		2003 -	RUJ-3011	RUJ-3011	RUJ-3011	REAR SHAFT
SCURRY		85-87	RUJ-1501		RUJ-1501	
SHUTTLE	WFR11, WFR51	82-86	K5-LGB80R		K5-LGB80R	IF EXTERNAL CIRCLIPS
		82-90	RUJ-2033		RUJ-2033	IF INTERNAL SNAP RINGS
STATESMAN	HQ 308 V8	71-74	RUJ-2030R		RUJ-2030R	
	HQ 350 V8	71-74	RUJ-2500R		RUJ-2500R	
	HJ, HX, HZ	74-79	RUJ-2500R		RUJ-2030R	
	WB	80-85	RUJ-2030R		RUJ-2030R	
	VQ, VR, VS STATESMAN/CAPRICE	90-6/99	RUJ-2038R	CV-855A	RUJ-2038R	
STATESMAN (cont.)	WH SERIES 1 STATESMAN/CAPRICE	7/99-8/01	RUJ-2038R	CV-855A	RUJ-2038R	
	WH SERIES 2, WK STATESMAN/CAPRICE V6 MPFI, WM	9/01 ON	RCA-1060	STAKED	RCA-1060	FRONT & REAR RUBBER DRIVE COUPLINGS
	WH SERIES 2, WK STATESMAN/CAPRICE V6 S/C, V8	9/01 ON	RCA-1061	STAKED	RCA-1061	FRONT & REAR RUBBER DRIVE COUPLINGS
	WM V8	9/06 ON	RCA-1062	STAKED	RCA1062	WH-WM SERIES 2, WK'S HAVE STAKED MIDDLE JOINTS (UNSERVICEABLE WITH OUT SPECIAL TOOLING) REFER HARDY SPICER SHAFT REPLACEMENT OPTIONS
SUBURBAN	K8 V8 DIESEL TURBO	98-01	5-178X		5-178X	
	K8 5.7L V8 PETROL	98-01	RUJ-3002		RUJ-3000	
TORANA (4 CYL)	HB	67-69	K5-LGB80R		K5-LGB80R	IF EXTERNAL CIRCLIPS
		67-69	RUJ-1786R		RUJ-1786R	IF INTERNAL SNAP RINGS
	LC, LJ, TA, LH, LX, UC (SUNBIRD)	70-80	RUJ-1786R		RUJ-1786R	
TORANA (6 CYL)	LC, LJ, LH, LX, UC	70-80	RUJ-1786R		RUJ-1786R	
TORANA (V8)	LH, LX,	74-78	RUJ-2030R		RUJ-2030R	

Document No:	HSDSCAT
Issue:	15
Issue Date:	03/11/14

APPLICATION LISTING



Make	Year	Joint Position			Notes
		Front	Middle	Rear	
HYUNDAI					
SANTA FE V6	SOME MODELS	GAH04-001-0		K5-A836	IF EXTERNAL CIRCLIPS
	CAN HAVE	GAH04-001-0		STAKED	UNSERVICEABLE WITHOUT SPECIAL TOOLING
TERRACAN	2004-2007	K5-A836		CV-874	FRONT SHAFT
TUCSON	SOME MODELS	GAH04-001-0		K5-A836	IF EXTERNAL CIRCLIPS
	CAN HAVE	GAH04-001-0		RUJ-2049	IF INTERNAL SNAP RINGS
	CAN HAVE	GAH04-001-0		STAKED	UNSERVICEABLE WITHOUT SPECIAL TOOLING
JAGUAR					
XJ6, XJ12, XJS	68-86	K5-13XR	K5-13XR	K5-13XR	
	87 ON	K5-A757	K5-A757	K5-A757	
	ALL	K5-GB10R			HALF SHAFT REAR
JEEP					
J10, J20 4X4	74-88	K5-13XR		K5-13XR	FRONT & REAR SHAFTS
		5-297X			WHEEL JOINTS FRONT AXLE
CHEROKEE	INCLUDING GRAND CHEROKEE	K5-13XR		K5-13XR	FRONT & REAR SHAFTS
		5-74X			WHEEL JOINTS FRONT AXLE W/OUT ANTI LOCK BRAKES
		5-297X			WHEEL JOINTS FRONT AXLE WITH ANTI LOCK BRAKES
CHEROKEE	3.7L AUTO	RUJ-3002		RUJ-3002	
WRANGLER	CJ, YJ	K5-13XR		K5-13XR	FRONT & REAR SHAFTS
		5-74X			WHEEL JOINTS FRONT AXLE
KIA					
CERES		RUJ-2049		RUJ-2049	
SPORTAGE	4 X 4	RUJ-2049		RUJ-2049	FRONT AND REAR SHAFT
	2.7 V6, 4 X 4	GAH04-001-0	CV-868	RUJ-2049	
LADA					
NIVA	4 X 4 WAGON (MOST 23.8MM CAP)	K5-LGB80R		K5-LGB80R	FRONT AND REAR SHAFT
	4 X 4 WAGON (SOME 28MM CAP)	K5-A676		K5-A676	FRONT AND REAR SHAFT
	4 X 4 WAGON	K5-A676		K5-A676	FRONT AND REAR SHAFT

Document No:	HSDSCAT
Issue:	15
Issue Date:	03/11/14

APPLICATION LISTING



Make	Year	Joint Position			Notes
		Front	Middle	Rear	
LEYLAND / MORRIS					
MINI 850, 1100, COOPER	AUTO	59-78	K5-GB150		INNER FWD SHAFT
	COOPER S FROM BODY 1918		K5-GB150		INNER FWD SHAFT
NOMAD	1300, 1500	69-72	114-2101		INNER FWD SHAFT MANUAL
		69-72	RUJ-1786R		INNER FWD SHAFT AUTO
MARINA	4 CYL	72-75	K5-GB150	K5-GB150	
	6 CYL	72-75	RUJ-1786R	RUJ-1786R	
P76	6 CYL	72-75	RUJ-1786R	RUJ-1786R	3 SPEED MANUAL, AUTO
	6 CYL	73-75	RUJ-2030R	RUJ-1786R	4 SPEED MANUAL
	V8	73-75	RUJ-2030R	RUJ-2038R	
MG	MGB, MGB GT	62-81	K5-LGB80R	K5-LGB80R	
	MGC, MGC GT, MGC V8	67-76	K5-13XR	K5-13XR	
MAZDA					
1200, 1300		67-77	RUJ-1784	RUJ-1784	
1500, 1800		67-74	RUJ-1784	RUJ-1784	
1600, CAPELLA		70-78	RUJ-1784	RUJ-1784 (SOME)	
121, 121L		76-80	RUJ-2049	RUJ-2049	
323	RWD	77-85	RUJ-1500	RUJ-1500	
626	CB2	78-83	RUJ-1784	RUJ-1784	SOME
808, SAVANNA		72-77	RUJ-1784	RUJ-1784	
929, 929L	LA2-LA4	74-84	RUJ-1784	RUJ-1784	
	HB, HBES	84-87	STAKED	STAKED	VEHICLES HAVE STAKED JOINTS (UNSERVICEABLE WITHOUT SPECIAL TOOLING) REFER HARDY SPICER
929, 929L cont.	HC, HD-E	87-97	STAKED	STAKED	VEHICLES HAVE STAKED JOINTS (UNSERVICEABLE WITHOUT SPECIAL TOOLING) REFER HARDY SPICER
BONGO	VAN	68-78		RUJ-2023	HALF SHAFTS
MPV	3.0L V6	4/96-	STAKED	STAKED	VEHICLES HAVE STAKED JOINTS (UNSERVICEABLE WITHOUT SPECIAL TOOLING) REFER HARDY SPICER
MX-5		89-	STAKED	STAKED	VEHICLES HAVE STAKED JOINTS (UNSERVICEABLE WITHOUT SPECIAL TOOLING) REFER HARDY SPICER

Document No:	HSDSCAT
Issue:	15
Issue Date:	03/11/14

APPLICATION LISTING



Make	Year	Joint Position			Notes	
		Front	Middle	Rear		
MAZDA cont.						
R100,RX-2,RX-3,RX-4	67-78	RUJ-1784	RUJ-1784 (SOME)	RUJ-1784		
RX-5	78-82	RUJ-2049	RUJ-2049	RUJ-2049		
RX-7	SERIES 1	RUJ-1784	RUJ-1784	RUJ-1784		
	SERIES 2,3	RUJ-2049	RUJ-2049	RUJ-2049	SOME SOME VEHICLES HAVE STAKED JOINTS (UNSERVICEABLE WITHOUT SPECIAL TOOLING)REFER HARDY SPICER	
	SERIES 4,5,6	STAKED	STAKED	STAKED	VEHICLES HAVE STAKED JOINTS (UNSERVICEABLE WITHOUT SPECIAL TOOLING)REFER HARDY SPICER	
RX-8	03-	STAKED	STAKED	STAKED	VEHICLES HAVE STAKED JOINTS (UNSERVICEABLE WITHOUT SPECIAL TOOLING)REFER HARDY SPICER	
B SERIES UTES	B1600, B1800 2WD	71-82	RUJ-2023	RUJ-2023	RUJ-2023	
	B2000 2WD	82-6/88	RUJ-2023	RUJ-2023	RUJ-2023	
	B2200 2WD	6/85-12/86	RUJ-2049	RUJ-2049	RUJ-2049	
	B2200 2WD	1/87-10/91	RUJ-2023	RUJ-2023	RUJ-2023	SOME MAY HAVE STAKED JOINTS IN FRONT AND REAR SOME VEHICLES HAVE STAKED JOINTS (UNSERVICEABLE WITHOUT SPECIAL TOOLING)REFER HARDY SPICER
	B2600 4X4	3/87-10/91	RUJ-2049	RUJ-2049	RUJ-2049	FRONT SHAFT
		3/87-10/91	RUJ-2023	RUJ-2023	RUJ-2023	REAR SHAFT SOME VEHICLES HAVE STAKED JOINTS IN REAR SHAFT (UNSERVICEABLE WITHOUT SPECIAL TOOLING)REFER HARDY SPICER
BRAVO	B2200,B2500,B2600 2WD	11/91-98	RUJ-2023	RUJ-2023	RUJ-2023	SOME VEHICLES HAVE STAKED JOINTS (UNSERVICEABLE WITHOUT SPECIAL TOOLING)REFER HARDY SPICER
	B2500, B2600	2/99-8/04	K5-13XR	K5-13XR	K5-13XR	
	B2500, B2600	9/04-10/06	RUJ-3002	RUJ-3002	RUJ-3002	
BRAVO	B2500, B2600 4X4	11/91-98	RUJ-2049	RUJ-2049	RUJ-2049	FRONT SHAFT
		11/91-98	RUJ-2023	RUJ-2023	RUJ-2023	REAR SHAFT
		99-8/04	RUJ-2049	RUJ-2049	RUJ-2049	FRONT SHAFT
		99-8/04	K5-13XR	K5-13XR	K5-13XR	REAR SHAFT SOME VEHICLES HAVE STAKED JOINTS IN REAR SHAFT (UNSERVICEABLE WITHOUT SPECIAL TOOLING)REFER HARDY SPICER
	B2500, B2600 4X4	9/04-10/06	K5-13XR	K5-13XR	K5-13XR	FRONT SHAFT
		9/04-10/06	K5-13XR	K5-13XR	K5-13XR	REAR SHAFT
	B4000 4X4	05-06	K5-13XR		CV JOINT	FRONT SHAFT (CV JOINT NOT CURRENTLY SERVICEABLE)
		05-06	CV JOINT	CV JOINT	CV JOINT	REAR SHAFT (FITTED WITH THREE CV JOINTS - NOT CURRENTLY SERVICEABLE)

Document No:	HSDSCAT
Issue:	15
Issue Date:	03/11/14

APPLICATION LISTING



Make	Year	Joint Position			Notes	
		Front	Middle	Rear		
MAZDA cont.						
BT-50	2.5DT, 3.0DT 2WD	11/06 ON	5-618XD	5-618XD	5-618XD	(HD LUBE IN CAP OPTION AVAILABLE ALSO - Part # 5-618-1XD)
	3.0DT 4X4	11/06 ON	K5-13XR		K5-13XR	FRONT SHAFT
		11/06 ON	5-618XD	5-618XD	5-618XD	REAR SHAFT (HD LUBE IN CAP OPTION AVAILABLE ALSO - Part # 5-618-1XD)
E SERIES VANS	E1300,E1400,E1600,E1800,E2200	71-12/83	RUJ-1784		RUJ-1784	INTERNAL CIRCLIPS SOME VEHICLES HAVE STAKED JOINTS (UNSERVICEABLE WITHOUT SPECIAL TOOLING)REFER HARDY SPICER
	E1800,E2200	84 ON	RUJ-2049		RUJ-2049	INTERNAL CLIPS SOME VEHICLES HAVE STAKED JOINTS (UNSERVICEABLE WITHOUT SPECIAL TOOLING)REFER HARDY SPICER
	E2000	84 ON	RUJ-1784		RUJ-1784	WITH DUAL REAR WHEELS
		84 ON	RUJ-2049		RUJ-2049	WITH SINGLE REAR WHEELS SOME VEHICLES HAVE STAKED JOINTS (UNSERVICEABLE WITHOUT SPECIAL TOOLING)REFER HARDY SPICER
TRIBUTE	AWD V6		K5-13XR		K5-13XR	
T SERIES TRUCKS	T2000	5/81-12/82	RUJ-3003	RUJ-3003	RUJ-3003	
	T2600	4/85-12/88	RUJ-3003	RUJ-3003	RUJ-3003	
	T3000	6/81-10/84	RUJ-3003	RUJ-3003	RUJ-3003	
	T3500	9/87-4/97	RUJ-3003	RUJ-3003	RUJ-3003	
	T4000	11/89-6/00	RUJ-4009	RUJ-4009	RUJ-4009	
	T4100	6/81-9/89	RUJ-4009	RUJ-4009	RUJ-4009	
	T4600	6/92-	RUJ-4009	RUJ-4009	RUJ-4009	
MITSUBISHI						
GALANT	GA	8/71-10/72	K5-A556		K5-A556	UP TO CF15
	GA, GB, GC, GD	11/72-12/77	RUJ-1786R		RUJ-1786R	GA(CF16 ON) GC,GD EXCEPT HARDTOP
	GC, GD	7/74-12/77	K5-A556		K5-A556	HARDTOP
LANCER	LA, LB, LC	9/74-8/81	K5-A556		K5-A556	
L200 EXPRESS UTE	MA, MB, MC, MD 1/2 TONNE 2WD	3/80-10/86	K5-A556	K5-A556	K5-A556	
	MA, MB, MC, MD 1 TONNE 2WD	3/80-10/86	RUJ-2045	RUJ-2045	RUJ-2045	
	MA, MB, MC, MD 4WD	6/81-10/86	K5-A556		K5-A556	FRONT SHAFT
		6/81-10/86	RUJ-2045		RUJ-2045	REAR SHAFT

Document No:	HSDSCAT
Issue:	15
Issue Date:	03/11/14

APPLICATION LISTING



Make	Year	Joint Position			Notes	
		Front	Middle	Rear		
MITSUBISHI cont.						
L300 EXPRESS VAN AND STARWAGON	SA-SE 2WD SC-WA 4WD	4/80-9/86 5/83-	K5-A556 K5-A556		K5-A556 K5-A556	FRONT SHAFT
	SC-WA 4WD	5/83-	RUJ-2045		RUJ-2045	REAR SHAFT
	SF-WA 2WD 2.0L	10/86-	K5-A556		K5-A556	
	SF-WA 2WD 2.4L PET, 2.5L DIESEL	10/86-	RUJ-2045		RUJ-2045	
PAJERO	NA, NG	1983-90	K5-A556		K5-A556	Exc LWB -V6 FRONT SHAFT
	NA, NG	1983-90	RUJ-2045		RUJ-2045	Exc LWB -V6 REAR SHAFT
	ND, NG	1986-91	K5-A556		K5-A556	LWB V6 ONLY FRONT SHAFT
	ND, NG	1986-91	RUJ-3006		RUJ-3006	LWB V6 ONLY REAR SHAFT
	NH, NJ	5/91-97	K5-A556		K5-A556	FRONT SHAFT
	NH, NJ TURBO DIESEL	5/91-97	RUJ-3006		RUJ-3006	FRONT SHAFT
	NH, NJ	5/91-97	RUJ-3006		RUJ-3006	REAR SHAFT
	NK, NM	11/96-11/02	K5-A556		K5-A556	FRONT SHAFT
	NK, NM DIESEL	11/96-11/02	RUJ-3006		RUJ-3006	REAR SHAFT
	NK, NM V6 PETROL & TURBO DIESEL	11/96-11/02	RUJ-4010		RUJ-4010	REAR SHAFT
SCORPION	GE	3/78-6/79	K5-A556		K5-A556	
	GH	7/79-10/80	RUJ-1786R		RUJ-1786R	
	GJ, GK, GL (MANUAL TRANSMISSION)	11/80-9/85	RUJ-1786R		RUJ-1786R	
	GJ, GK, GL (AUTO TRANSMISSION) MOST	11/80-9/85	RUJ-2045		RUJ-2045	76.5MM ACROSS CAPS
	GJ, GK, GL (AUTO TRANSMISSION) SOME	11/80-9/85	K5-A556		K5-A556	63.8MM ACROSS CAPS
SIGMA	GE, GH, GJ, GK, GN	10/77-12/87	RUJ-1786R		RUJ-1786R	
STARION	JA, JB, JD	82-87	RUJ-2045	RUJ-2045	RUJ-2045	
TRITON	ME, MF, MG, MH, MJ 2WD 4CYL	86 ON	RUJ-2045	RUJ-2045	RUJ-2045	MEASURE U/JOINT DIMENSIONS TO ENSURE CORRECT SIZE
	Some can have		K5-A556	K5-A556	K5-A556	MEASURE U/JOINT DIMENSIONS TO ENSURE CORRECT SIZE
	MJ 2WD V6	9/92 ON	RUJ-3006	RUJ-3006	RUJ-3006	
	ME, MF, MG 4WD	86-91	K5-A556		K5-A556	FRONT SHAFT
			RUJ-2045	RUJ-2045	RUJ-2045	REAR SHAFT (SOME V6 & TURBO DIESEL USE RUJ-3006)
	MH, MJ 4WD	9/92 ON	K5-A556		K5-A556	FRONT SHAFT
			RUJ-3006	RUJ-3006	RUJ-3006	REAR SHAFT
	MK, ML V6 & TURBO DIESEL		RUJ-4010	RUJ-4010	RUJ-4010	REAR SHAFT

Document No:	HSDSCAT
Issue:	15
Issue Date:	03/11/14

APPLICATION LISTING



Make	Year	Joint Position			Notes
		Front	Middle	Rear	
NISSAN					
	B10,B20	1967-70	RUJ-1780		RUJ-1780
1000-1200	B120	1970-74	RUJ-1780		RUJ-1780
	B120	1970-74	RUJ-1786R		RUJ-1786R
		1974-79	RUJ-1786R		RUJ-1786R
120Y, SUNNY	B210,VB210, B310	1974-81	RUJ-1780		RUJ-1780
			K5-A648		K5-A648
					AUSTRALIAN PRODUCTION
					SOME JAPANESE PRODUCTION
					SOME VEHICLES HAVE STAKED JOINTS (UNSERVICEABLE WITHOUT SPECIAL TOOLING)REFER HARDY SPICER
1600, 180B, 200B	510,610B,810B	1968-81	RUJ-1781		RUJ-1781
	510, 610B, 810B	1968-81	RUJ-1786R	RUJ-1786R	RUJ-1786R
	510,610B,810B	1968-81			RUJ-2028
					IRS HALF SHAFTS
2000, 2300, 2400		1966-73	RUJ-1781		RUJ-1781
240C,260C,280C,240K		1973-77	RUJ-1781	RUJ-1781	RUJ-1781
240K		1973-77			RUJ-2028
200SX		1994 on	TBA		TBA
					IRS HALF SHAFTS
					STAKED JOINTS
					VEHICLES HAVE STAKED JOINTS (UNSERVICEABLE WITHOUT SPECIAL TOOLING)REFER HARDY SPICER
240Z,260Z,280Z,280ZX		1967-86	RUJ-1781		RUJ-1781
					RUJ-2028
					IRS HALF SHAFTS
300ZX	Z31,Z32, Z31 TURBO	1986-97			
					STAKED JOINTS
					VEHICLES HAVE STAKED JOINTS
					(UNSERVICEABLE WITHOUT SPECIAL TOOLING) REFER HARDY SPICER
BLUEBIRD	910	1981-86	RUJ-1786R	RUJ-1786R	RUJ-1786R
GAZELLE	S12	1984-88			
					STAKED JOINTS
					VEHICLES HAVE STAKED JOINTS
					(UNSERVICEABLE WITHOUT SPECIAL TOOLING)REFER HARDY SPICER
NOMAD		1986-92	K5-A648		K5-A648
					STAKED JOINTS
					VEHICLES HAVE STAKED JOINTS
					(UNSERVICEABLE WITHOUT SPECIAL TOOLING)REFER HARDY SPICER
PINTARA	R31 MANUAL	1986-90	*100-R231	RUJ-1786R	RUJ-1786R
	R31 AUTO	1986-90	*100-R249	RUJ-1786R	RUJ-1786R
					*RUBBER COUPLING
					*RUBBER COUPLING

Document No:	HSDSCAT
Issue:	15
Issue Date:	03/11/14

APPLICATION LISTING



Make	Year	Joint Position			Notes
		Front	Middle	Rear	
NISSAN cont.					
SKYLINE	1978-80	RUJ-1781	RUJ-1781	RUJ-1781	
	1978-80			RUJ2028	IRS HALF SHAFTS
R30	1981-86				STAKED JOINTS
					VEHICLES HAVE STAKED JOINTS
					(UNSERVICEABLE WITHOUT SPECIAL TOOLING)REFER HARDY SPICER
R31	1986-88	RUJ-2030R	CV-856	RUJ-2030R	
R31	6/88-91	RUJ-2038R	CV-855A	RUJ-2038R	
STANZA	A10	RUJ-1781	RUJ-1781	RUJ-1781	JAPANESE PRODUCTION
	A10	RUJ-1786R	RUJ-1786R	RUJ-1786R	AUSTRALIAN PRODUCTION
COMMERCIAL					
520-620-720	1965-68	K5-LGB80R		K5-LGB80R	SOME
	1968-3/83	RUJ-1781	RUJ-1781	RUJ-1781	2WD&4WD
720	4/83-85	RUJ-2028	RUJ-2028	RUJ-2028	
CABALL	1971-81	RUJ-2028		RUJ-2028	
CABSTAR	PF22 PETROL	RUJ-1781		RUJ-1781	
	EF22 SD25 DIESEL	RUJ-2040		RUJ-2040	
NAVARA	D21 2WD Z20,Z24 PETROL	RUJ-1700	RUJ-1700	RUJ-1700	
	D21 2WD SD25.TD27 DIESEL	RUJ-1781		RUJ-1781	
	D21 4WD	RUJ-1781		RUJ-1781	FRONT SHAFT
	1985-8/87	RUJ-2028	RUJ-2028	RUJ-2028	REAR SHAFT
	D21 4WD	RUJ-1700		RUJ-1700	FRONT SHAFT
	8/87-2/97	RUJ-1700	RUJ-1700	RUJ-1700	REAR SHAFT
NAVARA	D22 4 Cyl 4WD	RUJ-1700		RUJ-1700	FRONT SHAFT
	D22 4 Cyl 2&4WD	RUJ-1700	RUJ-1700	RUJ-1700	REAR SHAFT
	D22 V6 3.0L 4WD	RUJ-1700		RUJ-1700	FRONT SHAFT
	D22 V6 3.0L, 3.0L DIESEL 2&4WD	RUJ-2028	RUJ-2028	RUJ-2028	REAR SHAFT
	D40 4WD 4.0L V6 PETROL	5--178XHD		5--178XHD	REAR SHAFT
	D40 4WD 2.5L TURBO DIESEL	RUJ-3002		RUJ-3002	REAR SHAFT
	D40 4WD	K5-13XR		K5-13XR	FRONT SHAFT (THAILAND MODELS) (WITH RUBBER BOOT FITTED ON SLIP)
	D40 4WD	K5-A757		K5-A757	FRONT SHAFT (SPANISH MODEL - CHASSIS PREFIX CVND40)

Document No:	HSDSCAT
Issue:	15
Issue Date:	03/11/14

APPLICATION LISTING



Make	Year	Joint Position			Notes
		Front	Middle	Rear	
NISSAN cont.					
PATHFINDER	4 Cyl WNY21	1986-8/87	RUJ-1781		FRONT SHAFT
	4 Cyl WNY21	1986-8/87	RUJ-2028	RUJ-2028	REAR SHAFT
	4 Cyl	8/87-8/92	RUJ-1700		FRONT SHAFT
	4 Cyl	8/87-8/92	RUJ-1700	RUJ-1700	REAR SHAFT
	V6 3.0L	8/92 -11/95	RUJ-1700		FRONT SHAFT
	V6 3.0L	8/92-11/95	RUJ-2028	RUJ-2028	REAR SHAFT
	V6 3.3L	11/1995 ON	RUJ-1700		FRONT SHAFT
	V6 3.3L	11/1995 - 5/2005	RUJ-2028	RUJ-2028	REAR SHAFT
	R51 4WD 4.0L V6 PETROL	5/2005 - ON	5--178XHD	5--178XHD	REAR SHAFT
	R51 4WD 2.5L TURBO DIESEL	5/2005 - ON	RUJ-3002	RUJ-3002	REAR SHAFT
	R51 4WD	5/2005 - ON	K5-A757	K5-A757	FRONT SHAFT
PATROL	G60	1959-80	5-178X	5-178X	FRONT & REAR SHAFT
	MQ	1980-87	RUJ-2028	RUJ-2028	FRONT & REAR SHAFT
	GQ 4.2L	1987-97	RUJ-3007	RUJ-3007	REAR SHAFT
	GQ 4.2L	1987-97	RUJ-2028	RUJ-2028	FRONT SHAFT
	GQ 3.0 & 2.8L	1989-97	RUJ-2028	RUJ-2028	FRONT & REAR SHAFT
	GU 2.8L TURBO DIESEL	12/97-5/00	RUJ-2028	RUJ-2028	FRONT & REAR SHAFT
	GU PETROL , DIESEL , TURBO DIESEL	12/97 ON	RUJ-2028	RUJ-2028	FRONT SHAFT
		12/97 ON	RUJ-3007	RUJ-3007	REAR SHAFT
TERRANO		1997-2000	TBA	TBA	STAKED VEHICLES HAVE STAKED JOINTS (UNSERVICEABLE WITHOUT SPECIAL TOOLING)REFER HARDY SPICER
URVAN	E20, E23	1974-86	RUJ-1781	RUJ-1781	
	E24	4/87-93	RUJ-1700	RUJ-1700	SOME VEHICLES HAVE STAKED JOINTS (UNSERVICEABLE WITHOUT SPECIAL TOOLING)REFER HARDY SPICER
UTE	XFN	1986-91	RUJ-2038R	RUJ-2038R	
VANETTE	C20	1974-80	RUJ-1780	RUJ-1780	SOME
	C20,C120	1980-86	RUJ-1781	RUJ-1781	SOME
					SOME VEHICLES HAVE STAKED JOINTS (UNSERVICEABLE WITHOUT SPECIAL TOOLING)REFER HARDY SPICER
X-TRAIL		11/00 ON	TBA	TBA	STAKED VEHICLES HAVE STAKED JOINTS (UNSERVICEABLE WITHOUT SPECIAL TOOLING)REFER HARDY SPICER

Document No:	HSDSCAT
Issue:	15
Issue Date:	03/11/14

APPLICATION LISTING



Make	Year	Joint Position			Notes
		Front	Middle	Rear	
ROVER					
80, 95, 100, 110, 2000, 3500, 3500S	1958-87	K5-13XR		K5-13XR	
2000, 3500, 3500S ONLY	1963-87			5-178X	IRS HALF SHAFT
LANDROVER	SERIES I & 11	1948-62	K5-L4R	K5-L4R	FRONT & REAR SHAFT
	SERIES I & 11	1948-62	K5-GB35		FRONT AXLE SWIVEL JOINT
	SERIES IIA & III	1962-84	K5-13XR	K5-13XR	FRONT & REAR SHAFT
	SERIES IIA & III	1962-84	K5-GB35		FRONT AXLE SWIVEL JOINT
	110 & DEFENDER	1984-86	K5-13XR	K5-13XR	FRONT & REAR SHAFT
	86 ON		K5-A757	K5-A757	FRONT & REAR SHAFT
	FREELANDER	3/98 ON	K5-GB150	K5-GB150	FRONT SHAFT
		3/98 ON	CVJ N/A	K5-GB150 X 2	3 PIECE REAR SHAFT
RANGEROVER	1972-85		K5-13XR	K5-13XR	FRONT & REAR SHAFT
	86 -		K5-A757	K5-A757	FRONT & REAR SHAFT
DISCOVERY	1991 ON		K5-A757	K5-A757	FRONT & REAR SHAFT
SUBARU					
FORESTER	AWD	8/97 ON			STAKED JOINTS VEHICLES HAVE STAKED JOINTS (UNSERVICEABLE WITHOUT SPECIAL TOOLING)REFER HARDY SPICER
IMPREZA	AWD	11/96 ON			STAKED JOINTS VEHICLES HAVE STAKED JOINTS (UNSERVICEABLE WITHOUT SPECIAL TOOLING)REFER HARDY SPICER
LEONE, BRUMBY	4WD	1972-94	RUJ-1796	RUJ-1796	RUJ-1796 VEHICLES HAVE STAKED JOINTS (UNSERVICEABLE WITHOUT SPECIAL TOOLING)REFER HARDY SPICER
LIBERTY, OUTBACK	AWD	1991 on	TBA	TBA	STAKED JOINTS VEHICLES HAVE STAKED JOINTS (UNSERVICEABLE WITHOUT SPECIAL TOOLING)REFER HARDY SPICER

Document No:	HSDSCAT
Issue:	15
Issue Date:	03/11/14

APPLICATION LISTING



Make	Year	Joint Position			Notes	
		Front	Middle	Rear		
SUZUKI						
L SERIES 4X4	LJ80,LJ81	1977-81	K5-A649		K5-A649	STAKED JOINTS
			RUJ-1795		RUJ-1795	SOME VEHICLES HAVE STAKED JOINTS (UNSERVICEABLE WITHOUT SPECIAL TOOLING)REFER HARDY SPICER
CARRY	SK410	1985-90	RUJ-1501		RUJ-1501	
SIERRA 4X4	SJ410	1981-	RUJ-1795		RUJ-1795	FRONT & REAR SHAFT
	SJ413	1985-	K5-A557		K5-A557	FRONT & REAR SHAFT
	SJ413	1985-	RUJ-1795		RUJ-1795	FRONT & REAR SHAFT
VITARA 4X4	SWB 1.6L	1988 on	K5-A557		K5-A557	FRONT & REAR SHAFT
	LWB 1.6L	1991 on	K5-A557		K5-A557	FRONT & REAR SHAFT
	LWB V6	1995 on	TBA		TBA	STAKED JOINTS
						VEHICLES HAVE STAKED JOINTS (UNSERVICEABLE WITHOUT SPECIAL TOOLING)REFER HARDY SPICER
GRAND VITARA 4X4	2.5L V6	99-2010	K5-A740		K5-A740	FRONT & REAR SHAFT
X90		1996 on	TBA		TBA	STAKED JOINTS
						VEHICLES HAVE STAKED JOINTS (UNSERVICEABLE WITHOUT SPECIAL TOOLING)REFER HARDY SPICER
TOYOTA						
GELICA	TA, RA Series	1971-83	RUJ-1776	RUJ-1776	RUJ-1776	
		Some	K5-A654	K5-A654	K5-A654	STAKED JOINTS
						SOME VEHICLES HAVE STAKED JOINTS (UNSERVICEABLE WITHOUT SPECIAL TOOLING)REFER HARDY SPICER
COROLLA	KE10-70	1967-83	K5-A517		K5-A517	JAPANESE PRODUCTION
		1967-81	RUJ-1786R		RUJ-1786R	AUSTRALIAN PRODUCTION
	KE70, AE70,71,72	11/81-85	RUJ-1786R	RUJ-1786R	RUJ-1786R	AUSTRALIAN PRODUCTION
	AE86 SPRINTER	1983-85	RUJ-2016	RUJ-2016	RUJ-2016	Japanese Production
	AE95 4X4	1988-95	RUJ-1776		RUJ-1776	Tail Shaft SOME
		1988-95	K5-A654		K5-A654	STAKED JOINTS
						SOME VEHICLES HAVE STAKED JOINTS (UNSERVICEABLE WITHOUT SPECIAL TOOLING)REFER HARDY SPICER
CORONA	RT40-RT118	1964-5/79	RUJ-1776	RUJ-1776	RUJ-1776	JAPANESE PRODUCTION
	RT132-RT142, ST141, XT130-133	6/79-87	RUJ-1786R	RUJ-1786R	RUJ-1786R	AUSTRALIAN PRODUCTION
			K5-A654	K5-A654	K5-A654	STAKED JOINTS
						SOME VEHICLES HAVE STAKED JOINTS (UNSERVICEABLE WITHOUT SPECIAL TOOLING)REFER HARDY SPICER

Document No:	HSDSCAT
Issue:	15
Issue Date:	03/11/14

APPLICATION LISTING



Make	Year	Joint Position			Notes
		Front	Middle	Rear	
TOYOTA cont.					
CORONA MKII	RT72, MX10-23 Series	1970-77	RUJ-1776		RUJ-1776
CRESSIDA	MX32-MX73	1977-88	RUJ-1776 K5-A654	RUJ-1776 K5-A654	RUJ-1776 K5-A654
					SOME STAKED JOINTS SOME VEHICLES HAVE STAKED JOINTS (UNSERVICEABLE WITHOUT SPECIAL TOOLING)REFER HARDY SPICER
CROWN	MS40,RS40	1964-68	RUJ-1776	RUJ-1776	RUJ-1776
	MS53,MS55,MS57,MS65	1968-74	RUJ-1786R	RUJ-1786R	RUJ-1786R
	MS83,MS85,MS111,MS112	1975-9/83	RUJ-2100HD	RUJ-2100HD	RUJ-2100HD
	MS83,MS85,MS111,MS112	1975-9/83	RUJ-2041HD	RUJ-2041HD	RUJ-2041HD
	MS123	10/83-88			
					JAPANESE PRODUCTION AUSTRALIAN PRODUCTION 29 MM CAPS 32 MM CAPS STAKED JOINTS VEHICLES HAVE STAKED JOINTS (UNSERVICEABLE WITHOUT SPECIAL TOOLING)REFER HARDY SPICER
LEXCEN	VN-VS	1989 on	RUJ-2038R	CV-855A	RUJ-2038R
RAV4		6/94-	K5-A654	K5-A654	K5-A654
					STAKED JOINTS VEHICLES HAVE STAKED JOINTS (UNSERVICEABLE WITHOUT SPECIAL TOOLING)REFER HARDY SPICER
SUPRA	MA60	1981-86	RUJ-1776	RUJ-1776	RUJ-1776
	MA70, MA71	1986-92	RUJ-2100HD	RUJ-2100HD	RUJ-2100HD
					SOME VEHICLES HAVE STAKED JOINTS (UNSERVICEABLE WITHOUT SPECIAL TOOLING)REFER HARDY SPICER
T18	TE72	1978-82	K5-A654		K5-A654
					STAKED JOINTS VEHICLES HAVE STAKED JOINTS (UNSERVICEABLE WITHOUT SPECIAL TOOLING)REFER HARDY SPICER
TARAGO	YR20,YR21,CR21 ON	1982-90	RUJ-1776		RUJ-1776
	YR20	1982-90	RUJ-2016		RUJ-2016
		1982-90	K5-A654		K5-A654
	TCR10, 11	9/90-5/00	RUJ-2100HD		RUJ-2100HD
					SOME TARAGO MODELS HAVE STAKED JOINTS (UNSERVICEABLE WITHOUT SPECIAL TOOLING)REFER HARDY SPICER
TERCEL	4WD	1983-88	K5-A654	K5-A654	K5-A654
					STAKED JOINTS VEHICLES HAVE STAKED JOINTS (UNSERVICEABLE WITHOUT SPECIAL TOOLING)REFER HARDY SPICER

Document No:	HSDSCAT
Issue:	15
Issue Date:	03/11/14

APPLICATION LISTING



Make	Year	Joint Position			Notes	
		Front	Middle	Rear		
TOYOTA cont.						
COMMERCIALS						
BLIZZARD	LD10	1982-83	K5-A522		K5-A522	FRONT & REAR SHAFTS (EXTERNAL CIRCLIPS)
			RUJ-2023		RUJ-2023	SOME HAVE (INTERNAL CIRCLIPS)
BUNDERA		1984-93	RUJ-2109HD		RUJ-2109HD	FRONT & REAR SHAFTS
COASTER	JU18, RU18	1969-72	K5-A519	K5-A519	K5-A519	
	BU19, RU19	1972-77	RUJ-2041HD	RUJ-2041HD	RUJ-2041HD	
	All	1977 on	RUJ-2041HD	RUJ-2041HD	RUJ-2041HD	
DYNA	All	1962-74	K5-A519	K5-A519	K5-A519	
	All	1974-84	RUJ-2041HD	RUJ-2041HD	RUJ-2041HD	
	Dyna 100	1986-01	RUJ-2016		RUJ-2016	
	Dyna 150	1985-88	RUJ-2109HD		RUJ-2109HD	
	Dyna 200, 300, 400	1985 on	RUJ-2041HD	RUJ-2041HD	RUJ-2041HD	
HIACE	RH, LH	1967-89	RUJ-2016		RUJ-2016	
	RZH/LH103,113	1989 on	RUJ-2100HD		RUJ-2100HD	SOME VEHICLES MAY HAVE STAKED JOINTS (UNSERVICEABLE WITHOUT SPECIAL TOOLING)REFER HARDY SPICER
HILUX 2WD						
	RN13-RN41, LN30-LN56, YN55-YN58, LN85, YN85	1968-88	RUJ-2016	RUJ-2016	RUJ-2016	
	2WD LN86, RN85, RN90, RZN147, 149, 154	1988 on	RUJ-2100HD	RUJ-2100HD	RUJ-2100HD	SOME HAVE RUJ-2016
	2WD KUN15 3.0, GGN15 4.0, TGN16R WORKMATE 2.7	3/05 ON	RUJ-2100HD	RUJ-2100HD	RUJ-2100HD	
HILUX 4WD, 4 RUNNER						
	4WD LN40, LN46	1979-7/83	RUJ-2100HD		RUJ-2100HD	REAR SHAFT
	4WD LN40, LN46	1979-7/83	RUJ-2100HD		RUJ-2100HD	REAR SHAFT
	4WD LN65, YN65, YN67, RN105, RN106, RN110, & RZN169, RZN174	8/83 ON	RUJ-2109HD		114-2501* X 2	FRONT SHAFT 13mm PIN CV-163
		8/83 ON	RUJ-2109HD	RUJ-2109HD	RUJ-2109HD	REAR SHAFT
	4WD VZN167R	10/01-2/05	RUJ-2109HD		114-2501* X 2	FRONT SHAFT 12mm PIN SCV-34
	4WD VZN167R	10/01-2/05	RUJ-2109HD	TBA	RUJ-2109HD	REAR SHAFT HAS A DOUBLE CARDAN ASSY IN MIDDLE
	4WD LN167	12/00 - 04	RUJ-2109HD		RUJ-2109HD	REAR SHAFT
	4WD LN167	12/00 - 04	RUJ-2109HD		114-2501* X 2	FRONT SHAFT
	4WD KUN26 3.0 DT, GGN25R 4.0 V6	3/05 ON	RUJ-2109HD		RUJ-2109HD	FRONT & REAR SHAFTS (SOME VEHICLES USE K5-13XR - EXTERNAL CIRCLIPS)

Document No:	HSDSCAT
Issue:	15
Issue Date:	03/11/14

APPLICATION LISTING



Make	Year	Joint Position			Notes	
		Front	Middle	Rear		
TOYOTA cont.						
LANDCRUISER	All	1965-1/74	K5-A519		K5-A519	FRONT & REAR SHAFTS
	All	1/74-1/90	RUJ-2041HD		RUJ-2041HD	FRONT & REAR SHAFTS
	75, 78, 79 SERIES	1/90 ON	RUJ-2109HD		RUJ-2109HD	FRONT SHAFT
	75, 78, 79 SERIES	1/90 ON	RUJ-2041HD		RUJ-2041HD	REAR SHAFT
	80 SERIES	1/90-12/99	RUJ-2109HD		RUJ-2109HD	FRONT SHAFT
	80 SERIES	1/90-12/99	RUJ-2041HD		RUJ-2041HD	REAR SHAFT
	100 SERIES	3/98 ON	RUJ-2109HD		RUJ-2109HD	FRONT SHAFT
	100 SERIES	3/98 ON	RUJ-2109HD		RUJ-2109HD	REAR SHAFT
	HDJ100, HZJ105, UZJ100, FZJ105	7/98-8/02	RUJ-2041HD		RUJ-2041HD	REAR SHAFT (SWING OUT BACK DOOR)
	UZJ100	2002-2006	RUJ-2109HD		RUJ-2109HD	REAR SHAFT
	G5J15 FJ CRUISER	2011-	RUJ-2109HD		RUJ-2109HD	FRONT & REAR SHAFTS
LITE ACE	All	1970-85	RUJ-1776		RUJ-1776	
		1985-	K5-A654		K5-A654	STAKED JOINTS SOME VEHICLES HAVE STAKED JOINTS (UNSERVICEABLE WITHOUT SPECIAL TOOLING) REFER HARDY SPICER
PRADO	All	1996 on	RUJ-2109HD		RUJ-2109HD	FRONT SHAFT
			114-2501*X 2		RUJ-2109HD	REAR SHAFT
* Double Cardan Assembly Requires 2 Pieces of 114-2501 and a Repair Kit -SCV34 with 12mm Pins, or CV-163 with 13mm Pins						
STOUT	RK101	1967-79	K5-A519		K5-A519	
	RK110	3/79-84	RUJ-2041HD		RUJ-2041HD	
TOWN ACE		1982-7/85	RUJ-2016		RUJ-2016	
		8/85-88	RUJ-2100HD		RUJ-2100HD	
SOME VEHICLES MAY HAVE STAKED JOINTS (UNSERVICEABLE WITHOUT SPECIAL TOOLING) REFER HARDY SPICER						

Document No:	HSDSCAT
Issue:	15
Issue Date:	03/11/14

APPLICATION LISTING



Make	Year	Joint Position			Notes
		Front	Middle	Rear	
TRIUMPH					
DOLOMITE	ALSO SPRINT	1975-78	K5-LGB80R		K5-LGB80R
SPITFIRE	GTS	1962-81	K5-LGB80R		K5-LGB80R
TR4		1961-66	K5-L4R		K5-L4R
TR4A, TR5, TR6		1966-77	K5-L4R		K5-L4R
STAG		1972-78	K5-L4R		K5-L4R
2000, 2500 MK1,2		1966-78	K5-LGB80R		K5-LGB80R
		1966-78	RUJ-1786R		RUJ-1786R
		1966-78			K5-L4R
TR7		1978-81	K5-LGB80R		K5-LGB80R
VOLVO					
140 SERIES	ALL	1967-73	K5-LGB80R		K5-LGB80R
	B20E, CB20	1973-75	K5-13XR	K5-13XR	K5-13XR
	B20, B20A	1973-75	K5-LGB80R	K5-LGB80R	K5L4R
160 SERIES	164E, 164TE, B30E	1972-75	K5-13XR	K5-13XR	K5-13XR
240 SERIES	B21A, B23E, B230E, B230F	1975-87	K5-LGB80R	K5-LGB80R	K5-L4R
	B21E	1975-80	K5-13XR	K5-13XR	K5-13XR
260 SERIES	262, 264, 265	1975-86	K5-13XR	K5-13XR	K5-13XR
740, 760 SERIES		1983-90	K5-13XR	K5-13XR	K5-13XR
		1983-90	K5-13XR	K5-L4R	K5-L4R
		1983-90	K5-L4R	K5-L4R	K5-L4R
					SOME
					SOME
					SOME

UNIVERSAL JOINT KITS

IDENTIFICATION OF UNIVERSAL JOINT KITS

DETERMINE KIT TYPE FROM ILLUSTRATIONS

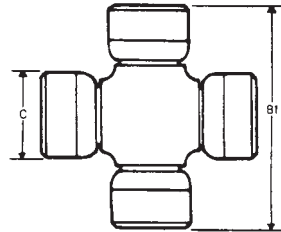

Fig.1

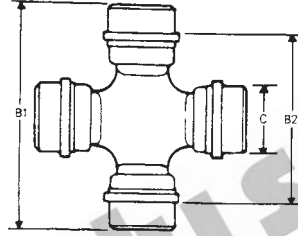

Fig.2

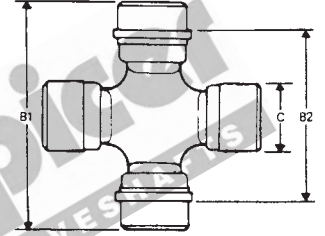

Fig.3

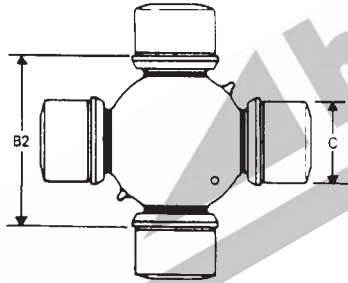

Fig.4

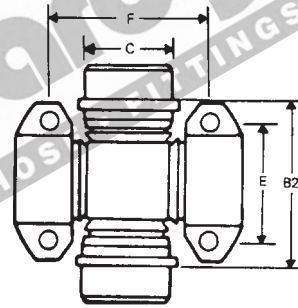

Fig.5

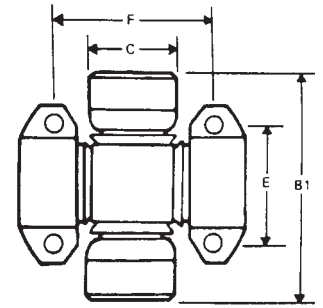

Fig.6

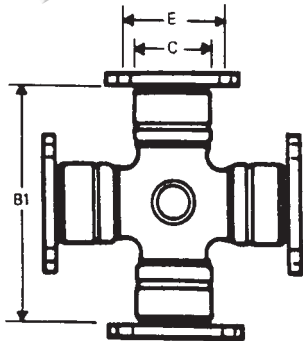

Fig.7

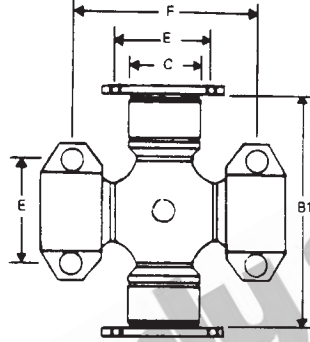

Fig.8

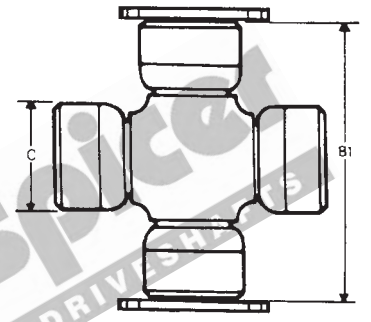

Fig.9

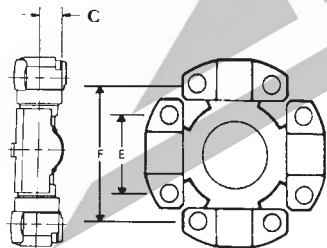

Fig.10

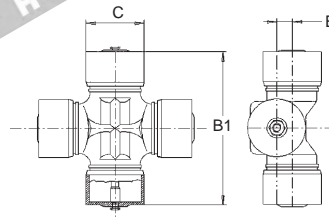

Fig.11

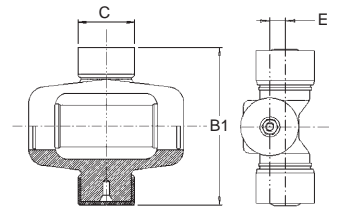

Fig.12

www.hardyspicer.com.au

Document No:	HSDSCAT
Issue:	15
Issue Date:	03/11/14

This catalogue is the copyright of Hardy Spicer

UNIVERSAL JOINT KITS

IDENTIFICATION OF BEARING TYPES & DIMENSIONS

BEARING TYPES & DIMENSIONS

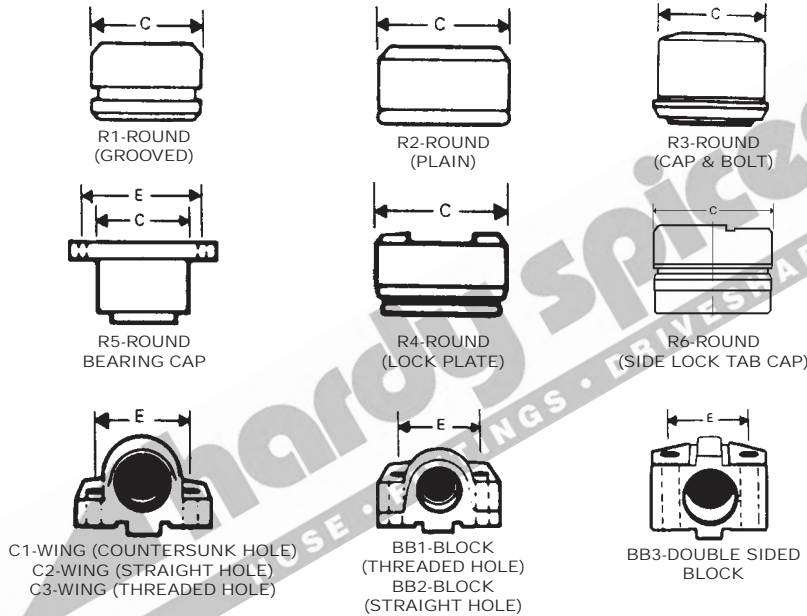

HOW TO MEASURE UNIVERSAL JOINT KITS

Follow these simple steps:-

STEP ONE

DETERMINE KIT TYPE FROM ILLUSTRATIONS

STEP TWO

Figures 1-4

- Measure Bearing Cap Diameter Dimension 'C'
- Measure 'B1' and/or 'B2'
- Check Bearing Cap Type and quantity.

Figures 5-9

- Measure Bearing Cap Diameter Dimension 'C'
- Measure 'B1' or 'B2'
- Measure Dimensions 'E' and/or 'F'
- Check Bearing Cap Type and quantity.

Figure 10

- Measure Dimensions 'E' and 'F'
- Check Bearing Cap Type and quantity.

IMPORTANT

Measure with Bearing Caps compressed-ensure that Needle Rollers are not dislodged.

NOTES

- | | |
|---|--|
| 1. Non Lubricated | 11. Lubed for life / Heavy Duty |
| 2. Lubricated - Side | 12. Kit supplied with only 2 Circlips |
| 3. Lubricated - Centre | 13. Kit supplied with only 2 Snap Rings |
| 4. Lubricated - Bearing Cap | 14. Use Strap Kit P/No. 5-70-28 |
| 5. 4 Snap Rings / 4 Circlips included | 15. Use Strap Kit P/No. 6-5-70-18 |
| 6. 3 Hole Bearing Plate Type | 16. Wheel Joint |
| 7. Uses 14.27mm (.562") Cap Screws | 17. Uses 19.05mm (.750") Cap Screws |
| 8. Uses 15.88mm (.625") Cap Screws | 18. Lubricated - Side Of Bearing Cap |
| 9. Centre Hole through UJ Kit | 19. Supplied with multiple sets of circlips. |
| 10. Measured inside face to inside face of Snap Rings | 20. Relief Valve in Centre of Cross |

www.hardyspicer.com.au

Document No:	HSDSCAT
Issue:	15
Issue Date:	03/11/14

This catalogue is the copyright of Hardy Spicer

UNIVERSAL JOINT KITS

IDENTIFICATION BY PART NUMBER

PART NUMBER	SEE REF. NUMBER	PART NUMBER	SEE REF. NUMBER	PART NUMBER	SEE REF. NUMBER
114-10003	1256	114-7126R	1164	5-326X	910
114-10007	1259	114-7205	1167	5-327X	913
114-10011	1261	114-7205R	1168	5-328X	610
114-10011PL	1262	114-7206	1175	5-330X	715
114-10033	1254	114-7207	1172	5-331X	712
114-1004	201	114-7207R	1173	5-332X	600
114-10500	1248	114-7208	1170	5-339XD	982
114-11002	1251	114-7209	1177	5-345X	517
114-12002	1266	114-7273	1158	5-346X	518
114-12002HD	1267	114-7294	721	5-347X	595
114-15002	1269	114-7295	1150	5-348X	598
114-15002W	1270	114-8014	724	5-355X	365
114-15002PL	1271	114-8113	1180	5-357X	516
114-15003	1272	114-8113PL	1181	5-407X	850
114-15003PL	1273	114-8113R	1182	5-433-1X	321
114-15500PL	1274	114-8205	1185	5-443X	301
114-1501	200	114-8205R	1186	5-460X	341
114-162	530	114-8206	1188	5-54X	958
114-2101	265	114-8207	1190	5-618XD	359
114-2107	277	114-8207R	1191	5-618-1XD	360
114-2110	1078	114-8209	1198	5-625XD	315
114-2111	268	114-8210	1200	5-627XD	491
114-2114	271	114-8211	1207	5-632XD	356
114-2116	1079	114-8508	1219	5-633XD	363
114-2117	1083	114-8508R	1220	5-634XD	350
114-2185	1081	114-8514	1217	5-641XD	511
114-232	439	114-8516	1212	5-674X	799
114-2501	432	114-8516HPL	1213	5-675X	841
114-3100	1087	114-8516R	1214	5-676X	859
114-3101	1088	114-9014HD	1222	5-677X	853
114-3102	442	114-9014R	1223	5-88X	601
114-3103	1089	114-9015	1226	CP35N-3	532
114-3105	437	114-9016	1228	CP55N	676
114-3105HD	438	114-9016PL	1229	CP58WB-29	1152
114-3120	443	114-9016R	1230	CP58WB-37	1156
114-3125	1086	114-9017	1233	CP58WB-38	1154
114-4100	1099	114-9017R	1234	CP6N	832
114-4103	1100	114-9026	1236	CP750N-1	706
114-4105	1093	114-9038	1232	CP7N	883
114-4107	451	114-9500	1239	CP850N-4	835
114-4110	1095	212213X	170	CP950N	947
114-4113	1097	5-124X	938	CPL10N-2	133
114-4156	453	5-134X	325	CPL14N	428
114-5031	1116	5-134XHDPL	326	CPL14N-1X	427
114-5109	559	5-150X	323	K5-13XR	316
114-5110	562	5-155X	602	K5-13XRHD	317
114-5122	1103	5-155XHD	603	K5-13XRHDPL	318
114-5127	1111	5-155XLFL	604	K5-A13XR	322
114-5132	565	5-165X	709	K5-A18R	493
114-5148	1105	5-170X	169	K5-A510	55
114-5154	568	5-178-4X	490	K5-A517	58
114-5173	1114	5-178X	487	K5-A519	430
114-5177	1108	5-178XHD	488	K5-A522	406
114-5177PL	1109	5-178XLHD	489	K5-A523	631
114-596	352	5-185X	916	K5-A530	349
114-6103	1130	5-186X	919	K5-A532	184
114-6104	1120	5-187X	922	K5-A536	527
114-6107	571	5-188X	592	K5-A537	343
114-6114	1132	5-212X	362	K5-A538	593
114-6114R	1133	5-213X	346	K5-A539	45
114-6128	1123	5-220X	605	K5-A541	496
114-6128PL	1124	5-221X	607	K5-A542	682
114-6128R	1125	5-248X	253	K5-A543	868
114-6135	569	5-252X	319	K5-A546	46
114-6143	1127	5-260X	347	K5-A547	745
114-6143R	1128	5-264X	130	K5-A548	898
114-6150	570	5-279X	798	K5-A549	61
114-6152	1136	5-280X	838	K5-A551	81
114-6162	1140	5-281X	856	K5-A553	103
114-6163	1143	5-297X	505	K5-A554	109
114-6164	1144	5-297-1X	506	K5-A556	205
114-6166	1146	5-297CL	507	K5-A557	208
114-6285	1138	5-3022X	351	K5-A558	214
114-7126	1162	5-308X	907	K5-A561	370
114-7126PL	1163	5-324X	862	K5-A562	424

www.hardyspicer.com.au

Document No:	HSDSCAT
Issue:	15
Issue Date:	03/11/14

This catalogue is the copyright of Hardy Spicer

UNIVERSAL JOINT KITS

PART NUMBER	SEE REF. NUMBER	PART NUMBER	SEE REF. NUMBER	PART NUMBER	SEE REF. NUMBER
K5-A563	531	K5-A637	43	K5-A714	985
K5-A564	554	K5-A638	664	K5-A715	1008
K5-A566	622	K5-A639	691	K5-A715-4X	1009
K5-A567	623	K5-A64	157	K5-A716	1026
K5-A568	625	K5-A643	949	K5-A717	1041
K5-A569	632	K5-A643-4X	950	K5-A717-4X	1042
K5-A571	634	K5-A643SF	951	K5-A718	1044
K5-A572	649	K5-A643W	952	K5-A718-4X	1045
K5-A573	694	K5-A644	320	K5-A719	1051
K5-A574	736	K5-A645	670	K5-A719-4X	1052
K5-A575	742	K5-A647	931	K5-A722	886
K5-A576	751	K5-A647W	932	K5-A722-4X	887
K5-A577	772	K5-A648	79	K5-A722SF	888
K5-A578	775	K5-A649	76	K5-A722W	889
K5-A579	781	K5-A650	106	K5-A723	581
K5-A580	790	K5-A651	112	K5-A724	477
K5-A581	793	K5-A652	127	K5-A725	686
K5-A582	811	K5-A653	124	K5-A726	552
K5-A583	874	K5-A654	121	K5-A727	382
K5-A584	890	K5-A655	190	K5-A727SF	383
K5-A585	475	K5-A656	197	K5-A728	521
K5-A586	778	K5-A657	187	K5-A728-4X	522
K5-A587	34	K5-A658	895	K5-A728W	523
K5-A588	91	K5-A659	880	K5-A729	587
K5-A589	94	K5-A660	637	K5-A730	588
K5-A590	376	K5-A661	62	K5-A730W-4X	589
K5-A591	519	K5-A662	784	K5-A730HT	590
K5-A592	538	K5-A665	700	K5-A730W	591
K5-A593	628	K5-A666	22	K5-A731	732
K5-A594	703	K5-A667	28	K5-A731-4X	733
K5-A595	726	K5-A668	1	K5-A731W	734
K5-A596	757	K5-A669	52	K5-A732	795
K5-A597	877	K5-A670	891	K5-A732-4X	796
K5-A598	814	K5-A671	86	K5-A732W	797
K5-A599	820	K5-A672	97	K5-A733	939
K5-A600	934	K5-A674	166	K5-A733SF	940
K5-A601	935	K5-A675	646	K5-A734	395
K5-A603	31	K5-A676	404	K5-A735	526
K5-A605	769	K5-A678	479	K5-A736	1022
K5-A606	763	K5-A679	556	K5-A736-4X	1023
K5-A607	750	K5-A680	577	K5-A737	998
K5-A609	145	K5-A681	580	K5-A737-4X	999
K5-A610	292	K5-A682	583	K5-A738	374
K5-A611	478	K5-A683	654	K5-A739	408
K5-A612	615	K5-A683HT	655	K5-A740	293
K5-A612HD	617	K5-A684	658	K5-A741	422
K5-A612-4X	616	K5-A685	661	K5-A742	729
K5-A614	748	K5-A686	735	K5-A743	948
K5-A615	88	K5-A687	766	K5-A747	1037
K5-A616	652	K5-A689	808	K5-A747-4X	1038
K5-A617	787	K5-A691	823	K5-A748	692
K5-A618	901	K5-A692	865	K5-A749	618
K5-A619	885	K5-A693	613	K5-A749-4X	619
K5-A620	927	K5-A694	904	K5-A749-4XRB	620
K5-A620-4X	928	K5-A695	946	K5-A749HT	621
K5-A620SF	929	K5-A696	847	K5-A752	864
K5-A620W	930	K5-A697	4	K5-A753	730
K5-A621	100	K5-A698	10	K5-A754	873
K5-A622	727	K5-A699	19	K5-A755	752
K5-A623	802	K5-A700	25	K5-A756	953
K5-A624	924	K5-A701	37	K5-A757	308
K5-A625	959	K5-A702	40	K5-A758	892
K5-A625	960	K5-A703	49	K5-A759	690
K5-A625-4X	961	K5-A704	826	K5-A760	480
K5-A626	964	K5-A705	7	K5-A760-2X	481
K5-A626W	965	K5-A706	16	K5-A761	1018
K5-A627	992	K5-A707	962	K5-A761-4X	1019
K5-A627W	993	K5-A707W	963	K5-A762	765
K5-A628	1015	K5-A708	978	K5-A763	657
K5-A628W	1016	K5-A708-4X	979	K5-A765	594
K5-A629	1032	K5-A708W	980	K5-A766	38
K5-A630	944	K5-A709	987	K5-A767	372
K5-A631	829	K5-A710	1011	K5-A768	933
K5-A632	679	K5-A710-4X	1012	K5-A769	650
K5-A633	805	K5-A711	1028	K5-A770	1070
K5-A634	954	K5-A711-4X	1029	K5-A771	614
K5-A635	13	K5-A712	1048	K5-A772	995
K5-A636	871	K5-A713	1057	K5-A772-4X	996

www.hardyspicer.com.au

Document No:	HSDSCAT
Issue:	15
Issue Date:	03/11/14

UNIVERSAL JOINT KITS

PART NUMBER	SEE REF. NUMBER	PART NUMBER	SEE REF. NUMBER	PART NUMBER	SEE REF. NUMBER
K5-A773	576	K5-A846	380	RUJ-2041HD-1X	546
K5-A774	455	K5-A847	390	RUJ-2045	211
K5-A775	955	K5-A849	1017	RUJ-2046	1085
K5-A776	287	K5-A850	412	RUJ-2049	298
K5-A777	198	K5-A851	957	RUJ-2050	413
K5-A778	770	K5-A852	144	RUJ-2051	426
K5-A779	831	K5-A853	389	RUJ-2052	414
K5-A780	884	K5-A854	192	RUJ-2053	415
K5-A781	651	K5-A855	749	RUJ-2054	401
K5-A782	707	K5-A856	182	RUJ-2078	547
K5-A783	731	K5-A857	1006	RUJ-2100	465
K5-A784	753	K5-GB10R	509	RUJ-2100HD	466
K5-A785	937	K5-GB10RHD	510	RUJ-2106	400
K5-A786	896	K5-GB150	160	RUJ-2109	467
K5-A788	528	K5-GB15R	688	RUJ-2109HD	468
K5-A789	968	K5-GB22R	685	RUJ-2110	463
K5-A789-4X	969	K5-GB35	313	RUJ-2113	469
K5-A790	1054	K5-L4R	307	RUJ-2114	409
K5-A791	1067	K5-LGB36R	310	RUJ-2500	435
K5-A791-4X	1068	K5-LGB80R-SP	161	RUJ-2500R	434
K5-A792	972	K5-LGB80R	163	RUJ-2503	436
K5-A793	810	RUJ-0500	26	RUJ-2505	454
K5-A794	792	RUJ-0600	168	RUJ-2507	328
K5-A795	483	RUJ-0602	64	RUJ-2508	411
K5-A796	656	RUJ-0603	70	RUJ-2509	472
K5-A797	429	RUJ-0604	66	RUJ-2527	396
K5-A798	431	RUJ-1500	142	RUJ-3000	361
K5-A799	533	RUJ-1501	118	RUJ-3001	502
K5-A800	558	RUJ-1503	139	RUJ-3002	358
K5-A801	975	RUJ-1504	115	RUJ-3003	541
K5-A802	956	RUJ-1505	116	RUJ-3004	584
K5-A803	768	RUJ-1506	117	RUJ-3005	643
K5-A804	553	RUJ-1700	392	RUJ-3006	484
K5-A805	582	RUJ-1701	196	RUJ-3007	549
K5-A806	894	RUJ-1702	232	RUJ-3009	574
K5-A807	1072	RUJ-1703	203	RUJ-3011	471
K5-A808	599	RUJ-1758	250	RUJ-3012	486
K5-A809	165	RUJ-1764	247	RUJ-4000	445
K5-A810	990	RUJ-1766	178	RUJ-4002	448
K5-A811	611	RUJ-1776	289	RUJ-4003	1091
K5-A812	394	RUJ-1780	67	RUJ-4005	452
K5-A813	893	RUJ-1781	226	RUJ-4007	529
K5-A814	794	RUJ-1784	223	RUJ-4008	514
K5-A815	482	RUJ-1786	238	RUJ-4009	640
K5-A816	524	RUJ-1786R	241	RUJ-4010	485
K5-A817	378	RUJ-1788	304	RUJ-4012	446
K5-A818-4X	1035	RUJ-1788-1X	305	RUJ-5001	739
K5-A819	499	RUJ-1795	220	RUJ-5002	760
K5-A820	1062	RUJ-1796	235	RUJ-5004	551
K5-A820-4X	1063	RUJ-1797	148	RUJ-5105	585
K5-A821	1075	RUJ-1798	256	RUJ-6047	586
K5-A822	1004	RUJ-1800	114	RUJ-6069	1148
K5-A823	689	RUJ-1801	179	RUJ-7000	1193
K5-A824	384	RUJ-2016	295	RUJ-7001	704
K5-A825	525	RUJ-2023	419	RUJ-7002	718
K5-A826	1001	RUJ-2027	340	RUJ-7003	624
K5-A827	791	RUJ-2028	416	RUJ-8001	697
K5-A830	612	RUJ-2028PL	417	RUJ-8002	1195
K5-A831	680	RUJ-2029	397	RUJ-8003	1205
K5-A832	761	RUJ-2030	259	RUJ-9902	1202
K5-A833	936	RUJ-2030R	262	RUJ-91110	1210
K5-A835	386	RUJ-2032	280	RUJ-11000	1245
K5-A836	388	RUJ-2033	460	RUJ-11500	1242
K5-A837	728	RUJ-2034	286	RUJ-12500	1264
K5-A838	421	RUJ-2036	461	RUJ-14001	1280
K5-A840	550	RUJ-2038	398	RUJ-14500	1277
K5-A841	557	RUJ-2038R	399	SPL170X	902
K5-A842	459	RUJ-2039	355	SPL170XW	903
K5-A843	368	RUJ-2040	229	SPL250X	941
K5-A844	54	RUJ-2041	544	SPL250XW	942
K5-A845	508	RUJ-2041HD	545	SPL250-SF3X	943

www.hardyspicer.com.au

Document No:	HSDSCAT
Issue:	15
Issue Date:	03/11/14

This catalogue is the copyright of Hardy Spicer

UNIVERSAL JOINT KITS

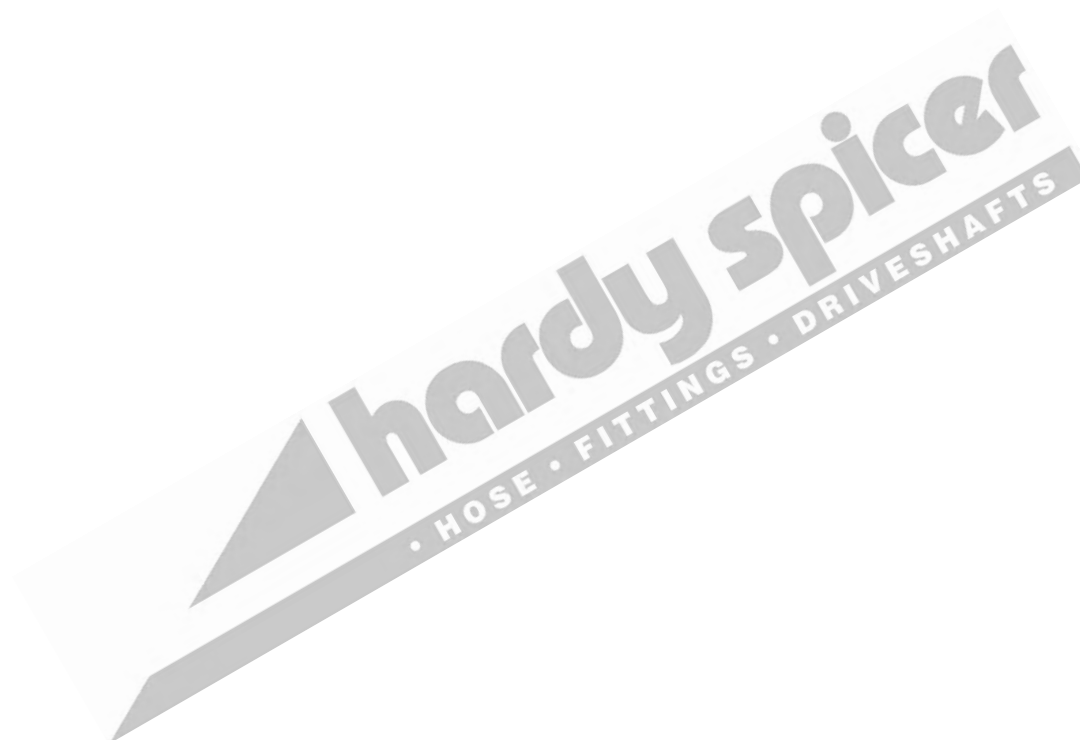

www.hardyspicer.com.au

Document No:	HSDSCAT
Issue:	15
Issue Date:	03/11/14

UNIVERSAL JOINT KITS

IDENTIFICATION BY PART SIZE

REF #	FIG	C	B1	B2	E	F	BEARING TYPE	PART #	SEE NOTES	DESCRIPTION
1	1	14.00	36.00				R2-4	K5-A668	3	ELBE 204 SERIES
4	1	15.00	38.00				R2-4	K5-A697	1	STAKED STEERING
7	1	15.00	39.00				R2-4	K5-A705	1	STAKED STEERING
10	1	15.00	40.00				R2-4	K5-A698	1	STAKED STEERING
13	1	15.00	40.20				R2-4	K5-A635	1	WILLI ELBE 058
16	1	15.00	40.20				R2-4	K5-A706	3	GWB 473-10
19	1	16.00	38.50				R2-4	K5-A699	1	STAKED STEERING
22	1	16.00	39.00				R2-4	K5-A666	1	STAKED STEERING
25	1	16.00	40.00				R2-4	K5-A700	1	STAKED STEERING
26	2	16.00		27.00			R1-4	RUJ-0500	4	KAWASAKI (REUSE OLD CLIPS)
28	1	17.00	41.00				R2-4	K5-A667	3	ELBE 105 SERIES
31	1	17.00	42.00				R2-4	K5-A603	3	GWB 173-10
34	1	18.00	47.00				R2-4	K5-A587	3	WALTERSCHEID W2000
37	1	19.00	44.00				R2-4	K5-A701	3	STEERING
38	1	19.00	44.40				R2-4	K5-A766	1	STAKED BMW MOTORCYCLE
40	1	19.00	48.00				R2-4	K5-A702	3	STAKED STEERING
43	1	19.00	48.00				R2-4	K5-A637	3	GWB 473-20 / ELBE 106
45	1	19.05	51.96				R2-4	K5-A539	1	500 SERIES NON LUBE
46	1	19.05	51.96				R2-4	K5-A546	3	500 SERIES CENTRE LUBE
49	1	20.00	44.20				R2-4	K5-A703	1	MOTO GUZZI
52	1	20.00	44.70				R2-4	K5-A669	1	KUBOTA
54	1	20.00	50.00				R2-4	K5-A844	3	MOWER DECK
55	1	20.00	55.00				R2-4	K5-A510	1	MAZDA
58	1	20.00	57.00				R2-4	K5-A517	1	TOYOTA
61	1	20.00	57.50				R2-4	K5-A549	3	JAPANESE PTO
62	1	20.00	58.00				R2-4	K5-A661	3	HINO
64	2	20.00		29.80			R1-4	RUJ-0602	3	JAPANESE PTO
66	2	20.00		37.00			R1-4	RUJ-0604	4	KUBOTA
67	2	20.00		38.10			R1-4	RUJ-1780	4	NISSAN
70	2	20.01		40.00			R1-4	RUJ-0603	1	TOYOTA T.C.M./KAWASAKI
76	1	20.07	59.80				R2-4	K5-A649	1	STAKED SUZUKI
79	1	20.07	52.40				R2-4	K5-A648	1	NISSAN
81	1	20.50	56.50				R2-4	K5-A551	3	JAP. STEERING & PTO
86	1	22.00	49.00				R2-4	K5-A671	1	MOTO GUZZI
88	1	22.00	50.20				R2-4	K5-A615	3	MOTO GUZZI
91	1	22.00	54.00				R2-4	K5-A588	3	T10 PTO
94	1	22.00	55.00				R2-4	K5-A589	3	WALTERSCHEID
97	1	22.00	58.00				R2-4	K5-A672	3	ELBE 107 SERIES
100	1	22.00	59.00				R2-4	K5-A621	3	GWB 473-30 SERIES
103	1	22.00	62.00				R2-4	K5-A553	3	JAPANESE PTO
106	1	22.00	64.00				R2-4	K5-A650	1	STAKED FORD
109	1	22.00	65.00				R2-4	K5-A554	1	HONDA
112	1	22.00	67.00				R2-4	K5-A651	1	STAKED FORD
114	2	22.00		35.10			R1-4	RUJ-1800	1	KAWASAKI M/CYCLES
115	2	22.00		35.50			R1-4	RUJ-1504	4	STAKED REP.TOY/NISSAN
116	2	22.00		38.50			R1-4	RUJ-1505	1	STAKED REPL. MAZDA
117	2	22.00		39.60			R1-4	RUJ-1506	4	FORKLIFTS
118	2	22.00		40.00			R1-4	RUJ-1501	1	MITS/TOY/FORKLIFT PTO
121	1	22.06	57.50				R2-4	K5-A654	1	TOYOTA
124	1	22.06	61.70				R2-4	K5-A653	1	ISUZU / MAZDA
127	1	22.06	64.50				R2-4	K5-A652	1	STAKED MITSUBISHI
130	1	22.20	73.60				R2-4	5-264X	3	1 FR SERIES
133	1	22.22	61.93				R2-4	CPL10N-2	4	L10N
139	2	22.50		37.50			R1-4	RUJ-1503	4	DAIHATSU LUBE IN CAP
142	2	22.50		37.65			R1-4	RUJ-1500	1	MAZDA
144	1	23.00	58.20				R2-4	K5-A852	1	STAKED MERC CENTRE HOLE
145	1	23.00	58.50				R2-4	K5-A609	3	GWB 273-30
148	2	23.00		49.00			R1-4	RUJ-1797	1	SUBARU
157	1	23.80	61.30				R2-4	K5-A64	3	1140 / T20 PTO
160	1	23.80	61.30				R2-4	K5-GB150	1	1140 AUTOMOTIVE
161	1	23.80	61.30				R2-4	K5-LGB80R-SP	4	1140 AUTO LUBE IN CAP

www.hardyspicer.com.au

Document No:	HSDSCAT
Issue:	15
Issue Date:	03/11/14

This catalogue is the copyright of Hardy Spicer

UNIVERSAL JOINT KITS

REF #	FIG	C	B1	B2	E	F	BEARING TYPE	PART #	SEE NOTES	DESCRIPTION
163	1	23.80	61.30				R2-4	K5-LGB80R	2	1140 AUTOMOTIVE
165	1	23.80	62.60				R2-4	K5-A809	1	B300/403 ELBE AXLE JOINT
166	1	23.80	65.90				R2-4	K5-A674	2	HINO STEERING
168	2	23.80		37.70			R1-4	RUJ-0600	3	0600 SERIES
169	2	23.80		38.10			R1-4	5-170X	3	1000 SERIES
170	2	23.80		38.10			R1-4	212213X	3	1000 SERIES PLASTIC BUSH
178	3	23.80	61.30				R2-2	RUJ-1766	4	1140 SERIES TO
	3	25.40		43.64			R1-2			17R SERIES
179	3	23.80	61.30				R2-2	RUJ-1801	1	1140 SERIES TO
	3	25.00		42.90			R1-2			SUZUKI
182	1	23.82	54.80				R2-4	K5-A856	1	UJ KIT TRIUMPH
184	1	24.00	63.30				R2-4	K5-A532	1	ALFA ROMEO
187	1	24.00	74.50				R2-4	K5-A657	1	STAKED MERCEDES
190	1	24.00	78.00				R2-4	K5-A655	1	STAKED FORD
192	1	24.00	88.00				R2-4	K5-A854	1	STAKED MERCEDES
196	2	24.00		48.00			R1-4	RUJ-1701	4	STAKED REPL. MAZDA
197	1	24.06	62.50				R2-4	K5-A656	1	STAKED BMW
198	1	24.06	71.40				R2-4	K5-A777	1	STAKED MAZDA
200	1	24.60		42.87			R1-4	114-1501	2	CATERPILLAR
201	2	24.61		36.80			R1-4	114-1004	3	L6N SERIES
203	2	24.70		41.70			R1-4	RUJ-1703	1	STAKED NISS/MAZ/TOY
205	1	25.00	63.80				R2-4	K5-A556	4	MAZDA / MITSUBISHI
208	1	25.00	64.00				R2-4	K5-A557	1	HONDA
211	1	25.00	76.50				R2-4	RUJ-2045	2	MITSUBISHI TRITON
214	1	25.00	77.00				R2-4	K5-A558	3	MITSUBISHI
220	2	25.00		42.90			R1-4	RUJ-1795	3	SUZUKI
223	2	25.00		43.60			R1-4	RUJ-1784	1	MAZDA
226	2	25.00		44.00			R1-4	RUJ-1781	1	NISSAN
229	2	25.00		56.00			R1-4	RUJ-2040	1	NISSAN
232	2	25.00		58.70			R1-4	RUJ-1702	1	TOYOTA T.C.M.
235	2	25.10		44.00			R1-4	RUJ-1796	1	SUBARU
238	2	25.40		43.64			R1-4	RUJ-1786	4	17R HOLDEN
241	2	25.40		43.64			R1-4	RUJ-1786R	1	17R HOLDEN H.D.
247	5	25.40		43.64			R1-2	RUJ-1764	4	EARLY HOLDEN
					33.34	44.45	C3-2			CHAMBERLAIN TRACTOR
250	5	25.40		43.64			R1-2	RUJ-1758	4	EARLY HOLDEN
					33.34	52.78	C3-2			17R SERIES
253	3	25.40		43.64			R1-2	5-248X	3	17R SERIES TO
		26.99	61.93				R2-2			1210 SERIES
256	2	25.40		46.80			R1-4	RUJ-1798	3	BENBOW PTO
259	2	25.40		59.53			R1-4	RUJ-2030	1	2R SERIES
262	2	25.40		59.53			R1-4	RUJ-2030R	1	2R SERIES H.D.
265	2	25.40		59.53			R1-4	114-2101	4	2R SERIES
268	5	25.40		59.53			R1-2	114-2111	2/4	2R SERIES TO
					33.34	59.53	C3-2			2C MECH
271	5	25.40		59.53			R1-2	114-2114	4	2R SERIES TO
					33.34	59.53	C1-2			2C MECH
277	5	25.40		59.53			R1-2	114-2107	2	2R SERIES
					33.34	61.52	C1-2			
280	3	25.40		59.53			R1-2	RUJ-2032	1	2R SERIES TO
		26.99	81.76				R2-2			1310 SERIES
286	2	25.40		59.53			R1-4	RUJ-2034	2	2R TO 25R SERIES
		28.58	81.76	59.53			R2-2			& FORD 1310
287	1	25.40	85.80				R2-4	K5-A776	3	KATO CRANE
289	2	26.00		46.60			R1-4	RUJ-1776	4	TOYOTA
292	1	26.00	69.80				R2-4	K5-A610	3	GWB 287-00
293	1	26.00	69.80				R2-4	K5-A740	4	GWB 287.00 LUBE IN CAP
295	2	26.00		55.96			R1-4	RUJ-2016	1	TOYOTA
298	2	26.50		50.40			R1-4	RUJ-2049	4	MAZDA E.2200
301	1	26.99	61.93				R2-4	5-443X	4	1210 SERIES
304	2	26.99		46.04			R1-4	RUJ-1788	3	12N SERIES
305	2	26.99		46.04			R1-4	RUJ-1788-1X	4	12N SERIES LUBE IN CAP
307	1	26.99	74.61				R2-4	K5-L4R	2	1300 SERIES
308	1	26.99	74.61				R2-4	K5-A757	2	1300 SERIES HEAVY DUTY
310	1	26.99	74.61				R2-4	K5-LGB36R	3	1300 / T40 PTO

www.hardyspicer.com.au

Document No:	HSDSCAT
Issue:	15
Issue Date:	03/11/14

This catalogue is the copyright of Hardy Spicer

UNIVERSAL JOINT KITS

REF #	FIG	C	B1	B2	E	F	BEARING TYPE	PART #	SEE NOTES	DESCRIPTION
313	1	26.99	74.61				R2-4	K5-GB35	1/16	1300 AXLE JOINT - NO SEALS
315	1	26.99	81.76				R2-4	5-625XD	1	1310 SERIES H/D Solid cross
316	1	26.99	81.76				R2-4	K5-13XR	2	1310 SERIES
317	1	26.99	81.76				R2-4	K5-13XRHD	2	1310 SERIES HEAVY DUTY
318	1	26.99	81.76				R2-4	K5-13XRHDPL	1	1310 Series H/D Solid cross
320	1	26.99	81.76				R2-4	K5-A644	2	1310 SERIES HIGH ANGLE
321	1	26.99	81.76				R2-4	5-433-1X	4	1310 SERIES LUBE IN CAP
322	1	26.99	81.76				R2-4	K5-A13XR	3	1310 SERIES PTO
323	1	26.99 28.58	81.76 92.08	65.10			R2-2 R1/R2-2	5-150X	2	1310 SERIES TO 1330 SERIES 9" DIFF/3R
325	1	26.99 26.99	81.76 92.08				R2-4	5-134X	2	1310 SERIES TO 1330 SERIES
326	1	26.99 26.99	81.76 92.08				R2-4	5-134XHDPL	1	1310 SERIES TO 1330 SERIES HEAVY DUTY
328	6	26.99	81.76				R2-2 C3-2	RUJ-2507	2	1310 SERIES TO 2C MECH
340	2	26.99	81.76	60.32			R1/R2-4	RUJ-2027	2/5	FORD CLEVELAND & 1280 SERIES
341	1	26.99 30.16	81.76 92.08				R2-4	5-460X	2	1310 x 1350 SERIES
343	1	26.99 30.16	92.08 92.08				R2-4	K5-A537	2	1330 SERIES TO 1350 SERIES
346	1	26.99	92.08				R2-4	5-213X	2	1330 SERIES
347	2	26.99		55.00			R1-4	5-260X	1	JEEP AXLE JOINT
349	3	26.99 27.38	81.76	54.00			R2-2 R1-2	K5-A530	2	1310 SERIES TO 21R SERIES
350	3	26.99 27.38	81.76	54.00			R2-2 R1-2	5-634XD	1	1310 SERIES TO 21R SERIES SOLID CROSS
351	3	26.99 28.58	81.76	65.10			R2-2 R1-2	5-3022X	2	1310 SERIES TO 3R
352	3	26.99 28.58	92.08	65.10			R2-2 R1-2	114-596	2	1330 SERIES TO 3R SERIES
355	1	26.99 28.58	81.76 81.76	59.53			R2-2 R1/R2-2	RUJ-2039	2	1310 SERIES TO 9" FORD DIFF & 25R
356	1	26.99 28.58	81.76 81.76				R2-4	5-632XD	1	1310 SERIES TO 9" FORD DIFF SOLID CROSS
358	2	26.99	92.08				R2-4	RUJ-3002	2	1330 SERIES
359	2	26.99	92.08				R2-4	5-618XD	1	1330 SERIES SOLID
360	2	26.99	92.08				R2-4	5-618-1XD	4	1330 H/D LUBE IN CAP
361	3	26.99 28.58	92.08 92.08				R2-4	RUJ-3000	2	1330 SERIES TO 1330 SERIES 9" DIFF
362	1	26.99 28.58	92.08	65.10			R2-2 R1-2	5-212X	2	1330 SERIES TO 3R
363	1	26.99 28.58	92.08 92.08				R2-4	5-633XD	1	1330 SERIES TO 1330 SERIES 9" DIFF SOLID
365	3	26.99 28.58	92.08	66.67			R2-2 R1-2	5-355X	2	1330 SERIES TO DETROIT 7290
368	1	27.00	62.00				R2-4	K5-A843	1	GREAT WALL
370	1	27.00	65.30				R2-4	K5-A561	4	MITSUBISHI
372	1	27.00	69.80				R2-4	K5-A767	1	VW SYNCHRO
374	1	27.00	70.00				R2-4	K5-A738	18	ELBE 408 SERIES AXLE
376	1	27.00	70.00				R2-4	K5-A590	3	T30 PTO
378	1	27.00	71.00				R2-4	K5-A817	1	B310 AXLE JOINT
380	1	27.00	74.00				R2-4	K5-A846	1	STAKED MERC SPRINTER
382	1	27.00	74.50				R2-4	K5-A727	3	GWB 687-15
383	1	27.00	74.50				R2-4	K5-A727SF	1	GWB 687-15
384	1	27.00	74.60				R2-4	K5-A824	1/16	BTB B210 AXLE JOINT
386	1	27.00	80.00				R2-4	K5-A835	1	STAKED VW/FORD
388	1	27.00	80.12				R2-4	K5-A836	2/20	HYUNDAI
389	1	27.00	85.00				R2-4	K5-A853	2	U/JOINT KIT
390	1	27.00	88.00				R2-4	K5-A847	1	STAKED MERC SPRINTER
392	2	27.00		49.02			R1-4	RUJ-1700	4	NISSAN NAVARA
394	1	27.00 32.00	91.00 76.00				R2-4	K5-A812	3	WALTERSCHEID 2480

www.hardyspicer.com.au

Document No:	HSDSCAT
Issue:	15
Issue Date:	03/11/14

This catalogue is the copyright of Hardy Spicer

UNIVERSAL JOINT KITS

REF #	FIG	C	B1	B2	E	F	BEARING TYPE	PART #	SEE NOTES	DESCRIPTION
395	1	27.00 27.00	91.20 85.80				R2-4	K5-A734	3	T40 WIDE ANGLE
396	3	27.39 28.58		54.00 66.67			R1-2 R1-2	RUJ-2527	1	21R SERIES TO 7290 DETROIT CHRYSLER
397	3	27.39 28.58	81.76	54.00			R1-2 R2-2	RUJ-2029	1	21R SERIES TO FORD 9" DIFF
398	2	27.39		54.00			R1-4	RUJ-2038	1	21R SERIES
399	2	27.39		54.00			R1-4	RUJ-2038R	1	21R SERIES PREMIUM
400	2	27.39		54.00			R1-4	RUJ-2106	3	MARINE STERN DRIVE
401	2	27.90		50.70			R1-4	RUJ-2054	1	STAKED REPL. NISSAN
404	1	28.00	71.50				R2-4	K5-A676	4	ELBE 109 SERIES (OLD)
406	1	28.00	80.00				R2-4	K5-A522	3	DAIHATSU
408	1	28.00 26.99	80.00 81.76				R2-4	K5-A739	2	DAIHATSU / 1310
409	3	28.00 26.99	81.76	55.96			R1-2 R2-2	RUJ-2114	2	NISSAN TO 1310 SERIES
411	2	28.00		48.00			R1-4	RUJ-2508	2	FORD UK
412	2	28.00		51.60			R1-4	K5-A850	4	KIA SORENTO
413	2	28.00		53.00			R1-4	RUJ-2050	2	MERCEDES BENZ
414	2	28.00		53.00			R1-4	RUJ-2052	1/9	BENZ HOLE IN CROSS
415	2	28.00		54.00			R1-4	RUJ-2053	2	MERCEDES BENZ
416	2	28.00		55.96			R1-4	RUJ-2028	2	NISSAN
417	2	28.00		55.96			R1-4	RUJ-2028PL	1	NISSAN H/DUTY NON-LUBE
419	2	28.00		59.10			R1-4	RUJ-2023	2	MAZDA
421	1	28.50	70.70				R2-4	K5-A838	3	ELBE 408
422	1	28.50	70.90				R2-4	K5-A741	3	ELBE 109 (NEW)
424	1	28.50	78.00				R2-4	K5-A562	3	MITSUBISHI
426	2	28.55		65.40			R1-4	RUJ-2051	2	GWB 185-10
427	1	28.58	66.67				R2-4	CPL14N-1X	4	2000 P.T.O. LUBE IN CAP
428	1	28.58	66.67				R2-4	CPL14N	3	2000 P.T.O. SERIES
429	1	28.58	66.68 28.58	107.95			R2-4	K5-A798	3	WEASLER 14 CVJ
430	1	28.58	77.90				R2-4	K5-A519	3	TOYOTA
431	1	28.58	107.95 31.75	81.76			R2-4	K5-A798	3	WEASLER 35 CVJ
432	2	28.58		54.00			R1-4	114-2501	4	25R JAP CARDAN
434	2	28.58		59.53			R1-4	RUJ-2500R	1	25R SERIES HD
435	2	28.58		59.53			R1-4	RUJ-2500	1	25R SERIES
436	2	28.58		59.53			R1-4	RUJ-2503	4	25R SERIES LUBE
437	2	28.58		65.10			R1-4	114-3105	2	3R SERIES
438	2	28.58		65.10			R1-4	114-3105HD	1	3R SERIES SOLID CROSS
439	2	28.58		66.67			R1-4	114-232	2	CHRYSLER JOINT
442	5	28.58		65.10	36.52	69.85	R1-2 C3-2	114-3102	2	3R SERIES TO 3C MECH WT
443	5	28.58		65.10	36.52	69.85	R1-2 BB2-2	114-3120	2	3R SERIES TO 3C MECH BLOCK
445	2	28.58		82.55			R1-4	RUJ-4000	2	4R SERIES
446	5	28.58		82.55	42.85	88.90	R1-2 BB2-2	RUJ-4012	2	4R TO 5C MECH MITS FORKLIFT (HS-S4S-N)
448	5	28.58		82.55	36.52	87.32	R1-2 C1-2	RUJ-4002	2	4R TO 4C MECH COUNTER SUNK HOLES
451	5	28.58		82.55	36.52	87.32	R1-2 C1-2	114-4107	2	4R SERIES TO 4C MECH
452	5	28.58		82.55	36.52	87.32	R1-2 C3-2	RUJ-4005	2	4R SERIES TO 4C MECH
453	5	28.58		82.55	36.52	87.32	R1-2 BB2-2	114-4156	2	4R SERIES TO 4C MECH
454	2	28.60		65.10			R1-4	RUJ-2505	2	DAIHATSU / FURKAWA
455	1	28.60	74.60				R2-4	K5-A774	1	FIAT 130
459	1	29.00	76.60				R2-4	K5-A842	1	GREAT WALL
460	2	29.00		53.10			R1-4	RUJ-2033	2	ISUZU / HOLDEN
461	2	29.00		53.10			R1-4	RUJ-2036	4	ISUZU / HOLDEN
463	3	29.00 26.99	81.76	53.10			R1-2 R2-2	RUJ-2110	2	ISUZU TO 1310 SERIES
465	2	29.00		52.00			R1-4	RUJ-2100	4	TOYOTA HILUX 4WD

www.hardyspicer.com.au

Document No:	HSDSCAT
Issue:	15
Issue Date:	03/11/14

This catalogue is the copyright of Hardy Spicer

UNIVERSAL JOINT KITS

REF #	FIG	C	B1	B2	E	F	BEARING TYPE	PART #	SEE NOTES	DESCRIPTION
466	2	29.00		52.00			R1-4	RUJ-2100HD	4	TOYOTA HILUX 4WD H/DUTY
467	2	29.00		52.00			R1-4	RUJ-2109	3	TOYOTA HILUX 4WD
468	2	29.00		52.00			R1-4	RUJ-2109HD	3	TOYOTA 4WD HEAVY DUTY
469	3	29.00 26.99	81.76	52.00			R1-2 R2-2	RUJ-2113	2	TOYOTA HILUX 4WD TO 1310 SERIES
471	2	29.02		72.00			R1-4	RUJ-3011	4	HOLDEN JACKEROO
472	2	29.50		56.00			R1-4	RUJ-2509	2	MERCEDES BENZ
475	1	30.00	78.20				R2-4	K5-A585	3	MINI COOPER
477	11	30.00	79.00		5.00		R2-4	K5-A724	16/18	ELBE 509 SERIES OFFSET
478	1	30.00	81.80				R2-4	K5-A611	3	GWB 287-10
479	1	30.00	83.00				R2-4	K5-A678	16/18	ELBE 409 SERIES
480	1	30.00	83.00				R2-4	K5-A760	3	ELBE 110 SERIES
481	1	30.00	83.00				R2-4	K5-A760-2X	4	ELBE 110 2 x Lube in Cap
482	12	30.00	96.00		6.00		R2-4	K5-A815	1	GWB 369.10 AXLE JOINT
483	2	30.00		46.00			R1-4	K5-A795	1	U/J KIT
484	2	30.00		58.30			R1-4	RUJ-3006	3	MINI COOPER
485	2	30.00		74.20			R1-4	RUJ-4010	3	MINI COOPER
486	2	30.00		60.00			R1-4	RUJ-3012	2	FARMLINER (AGI)
487	1	30.16	92.08				R2-4	5-178X	2	1350 SERIES
488	1	30.16	92.08				R2-4	5-178XHD	1	1350 SERIES HEAVY DUTY
489	1	30.16	92.08				R2-4	5-178XLHD	2	1350 HEAVY DUTY WITH LUBE
490	1	30.16	92.08				R2-4	5-178-4X	4	1350 LUBED IN 4 x CAPS
491	1	30.16	92.08				R2-4	5-627XD	1	1350 SERIES H/D Solid Cross
493	1	30.20	92.08				R2-4	K5-A18R	3	1350 / T60 PTO
496	1	30.16 28.58	92.08 92.08				R2-4	K5-A541	2	1350 SERIES TO 1330F SERIES 9" DIFF
499	1	30.16 30.16	92.08 106.30				R2-4	K5-A819	1	1350 SERIES TO 1410 SERIES U/J
502	3	30.16 30.16	92.08	65.10			R2-2 R1-2	RUJ-3001	2	FORD F500 SERIES
505	2	30.16		55.57			R1-4	5-297X	1/16	1350 AXLE JOINT
506	2	30.16		55.57			R1-4	5-297-1X	4/16	AXLE JOINT LUBE IN CAP
507	2	30.16		55.57			R1-4	5-297CL	3/16	AXLE JOINT CENTRE LUBE
508	2	30.16		61.08			R1-4	K5-A845	16	AXLE JOINT JEEP 68017182AA
509	1	30.16	106.30				R2-4	K5-GB10R	2	1410 SERIES
510	1	30.16	106.30				R2-4	K5-GB10RHD	2	1410 SERIES HEAVY DUTY
511	1	30.16	106.30				R2-4	5-641XD	1	1410 LUBE FOR LIFE
514	3	30.16 30.16	106.30	79.37			R2-2 R1-2	RUJ-4008	2	S55 TO 1410 SERIES CAN BE 4xGREASE IN CAP
516	3	30.16 31.35	106.30	76.20			R2-2 R1-2	5-357X	2	1410 SERIES TO 5380 DETROIT
517	6	30.16	106.30		36.52	87.32	R2-2 BB2-2	5-345X	2	1410 SERIES TO 4C MECH - 2 x BLOCK (Str)
518	6	30.16	106.30		36.52	87.32	R2-2 C3-2	5-346X	2	1410 SERIES TO 4C MECH-2 x WING (Thread)
519	1	30.20	80.00				R2-4	K5-A591	3	T50 PTO
521	1	30.20	81.80				R2-4	K5-A728	3	GWB 687-20 SERIES
522	1	30.20	81.80				R2-4	K5-A728-4X	4	GWB 687-20 LUBE IN 4 CAPS
523	1	30.20	81.80				R2-4	K5-A728W	3	GWB 687-20 SERIES
524	1	30.20	82.00				R2-4	K5-A816	1/16	B320 WHEEL JOINT
525	1	30.20	99.40				R2-4	K5-A825	4	BYPY 6 CV70 UJ KIT
526	1	30.20 30.20	101.40 95.35				R2-4	K5-A735	3	T60 WIDE ANGLE
527	1	30.20	106.30				R2-4	K5-A536	3	1410 SERIES PTO
528	1	31.00	110.00				R2-4	K5-A788	1	MERCEDES
529	2	31.25		76.20			R1-4	RUJ-4007	2	5380 DETROIT
530	2	31.35		50.80			R1-4	114-162	2	CHRYSLER
531	1	31.70	102.00				R2-4	K5-A563	3	MINI COOPER
532	1	31.75	81.36				R2-4	CP35N-3	3	ROCKWELL
533	1	31.75 31.75	81.76 109.54				R2-4	K5-A799	3	WEASLER 44 CVJ
538	1	32.00	76.00				R2-4	K5-A592	3	WALTERSCHEID
541	2	32.00		59.92			R1-4	RUJ-3003	3	MAZDA
544	2	32.00		64.00			R1-4	RUJ-2041	2	TOYOTA LANDCRUISER

www.hardyspicer.com.au

Document No:	HSDSCAT
Issue:	15
Issue Date:	03/11/14

This catalogue is the copyright
of Hardy Spicer

UNIVERSAL JOINT KITS

REF #	FIG	C	B1	B2	E	F	BEARING TYPE	PART #	SEE NOTES	DESCRIPTION
545	2	32.00		64.00			R1-4	RUJ-2041HD	2	TOYOTA L/CRUISER H/D
546	2	32.00		64.00			R1-4	RUJ-2041HD-1X	4	TOYOTA L H/D LUBE IN CAP
547	3	32.00 30.16	92.08	63.85			R1-2 R2-2	RUJ-2078	4	TOYOTA LANDCRUISER TO 1350 SERIES
549	2	32.00		68.00			R1-4	RUJ-3007	2	NISSAN PATROL 1988 -
550	2	32.00		87.00			R1-4	K5-A840	2	FURUKAWA
551	5	32.00		87.00	42.85	88.90	R1-2 BB2-2	RUJ-5004	2	FURUKAWA
552	1	32.00	86.00				R2-4	K5-A726	2	JOHN DEERE
553	1	32.00	95.60				R2-4	K5-A804	3	JCB
554	1	32.00	107.00				R4-4	K5-A564	2	NISSAN INCL 4 LOCK TABS REUSE BOLTS & PLATES
556	1	33.00	93.00				R2-4	K5-A679	3	ISUZU
557	1	33.00	103.00				R2-4	K5-A841	3	ISUZU
558	3	33.33 38.89	94.46	79.77			R1-2 R2-2	K5-A800	3	WEASLER 55 CVJ
559	2	33.35		84.15			R1-4	114-5109	2	5R SERIES
562	5	33.35		84.15	42.85	88.90	R1-2 C2-2	114-5110	2	5R SERIES TO 5C MECH
565	5	33.35		84.15	42.85	88.90	R1-2 C3-2	114-5132	2	5R SERIES TO 5C MECH
568	5	33.35		84.15	42.85	88.90	R1-2 BB2-2	114-5154	2	5R SERIES TO 5C MECH
569	2	33.35		109.55			R1-4	114-6135	2	6R SERIES
570	5	33.35		109.55	42.85	114.30	R1-2 BB2-2	114-6150	2	6R SERIES TO 6C MECH-2 x BLOCK (Str)
571	5	33.35		109.55	42.85	114.30	R1-2 C3-2	114-6107	2	6R SERIES TO 6C MECH-2 x WING (Thread)
574	2	33.35		70.64			R1-4	RUJ-3009	3	WEASLER 44 SERIES
576	1	34.00	89.00				R2-4	K5-A773	3	UNIMOG
577	1	34.00	96.00		6.00		R2-4	K5-A680	4/16	ELBE 511 - OFFSET
580	1	34.00	97.00				R2-4	K5-A681	4	ELBE 112 SERIES (OLD)
581	1	34.00	97.00				R2-4	K5-A723	16/18	ELBE 112 SERIES (OLD) LUBE ON SIDE OF CAP
582	1	34.00 35.00	97.00				R2-4	K5-A805	3	ELBE 112 OLD - 112 NEW
583	1	34.00	107.00				R2-4	K5-A682	3	TOYOTA
584	2	34.00		56.00			R1-4	RUJ-3004	3	WALTERSCHEID
585	5	34.00		84.15	42.85	88.90	R1-2 BB2-2	RUJ-5105	2	U/J KIT-TOY/MTS FORKLIFT
586	5	34.00		109.55	42.85	114.30	R1-2 BB2-2	RUJ-6047	2	U/J KIT-FURUKAWA / KOMATSU
587	1	34.90	92.00				R2-4	K5-A729	3	GWB 687-25
588	1	34.90	106.40				R2-4	K5-A730	3	GWB 687-30
589	1	34.90	106.40				R2-4	K5-A730W-4X	4	GWB 687-30 LUBE IN 4 CAPS
590	1	34.90	106.40				R2-4	K5-A730HT	3	GWB 687-30 HIGH TEMP
591	1	34.90	106.40				R2-4	K5-A730W	3	GWB 687-30
592	1	34.93	106.30				R2-4	5-188X	2	1480 SERIES
593	1	34.93	106.30				R2-4	K5-A538	3	1480 / T80 PTO
594	1	34.93 34.93	106.30 113.80				R2-4	K5-A765	3	T80 SERIES PTO WIDE ANGLE
595	6	34.93	106.30		42.85	88.90	R2-2 BB2-2	5-347X	2	1480 SERIES TO 5C MECH - 2 x BLOCK (Str)
598	6	34.93	106.30		42.85	88.90	R2-2 C3-2	5-348X	2	1480 SERIES TO 5C MECH-2xWING(Thread)
599	2	34.93		74.17			R1-4	K5-A808	1/16	AAM1485 AXLE JOINT
600	2	34.93		76.20			R1-4	5-332X	2/16	1480 AXLE JOINT
601	2	34.93		76.20			R1-4	5-88X	1/16	1480 AXLE JOINT
602	1	34.93	126.20				R2-4	5-155X	2	1550 SERIES
603	1	34.93	126.20				R2-4	5-155XHD	2	1550 SERIES HEAVY DUTY
604	1	34.93	126.20				R2-4	5-155XLFL	1	1550 SERIES LUBE FOR LIFE
605	6	34.93	126.20		42.85	114.30	R2-2 BB1-2	5-220X	2	1550 SERIES TO 6C MECH 2 x DELTA WING (Thread)
607	6	34.93	126.20		42.85	114.30	R2-2 BB2-2	5-221X	2	1550 SERIES TO 6C MECH - 2xBLOCK (Str)

www.hardyspicer.com.au

Document No:	HSDSCAT
Issue:	15
Issue Date:	03/11/14

This catalogue is the copyright of Hardy Spicer

UNIVERSAL JOINT KITS

REF #	FIG	C	B1	B2	E	F	BEARING TYPE	PART #	SEE NOTES	DESCRIPTION
610	6	34.93	126.20		49.21	107.50	R2-2 BB2-2	5-328X	2	1550 SERIES TO 58WB SERIES-2xBLOCK(Str)
611	5	35.00	104.50		43.00	83.50	R2-2 BB2-2	K5-A811	2	MITSUBISHI FORKLIFT SUITS SHAFT HS-S4S
612	11	35.00	87.00		7.00		R2-4	K5-A830	16/18	ELBE 510 AXLE JOINT
613	1	35.00	94.00				R2-4	K5-A693	3	BYPY
614	11	35.00	96.00		6.00		R2-4	K5-A771	4/16	ELBE 511 SERIES (NEW)
615	1	35.00	96.80				R2-4	K5-A612	3	GWB 587-10
616	1	35.00	96.80				R2-4	K5-A612-4X	4	GWB 587-10 LUBE IN 4 CAPS
617	1	35.00	96.80				R2-4	K5-A612HD	3	GWB 587-10 HEAVY DUTY
618	1	35.00	97.00				R2-4	K5-A749	3	ELBE 112 (NEW)
619	1	35.00	97.00				R2-4	K5-A749-4X	4	ELBE 112 LUBE IN 4 CAPS
620	1	35.00	97.00				R2-4	K5-A749-4XRB	4	ELBE 112 ROLLER BRG
621	1	35.00	97.00				R2-4	K5-A749HT	4	ELBE 112 HIGH TEMP
622	1	35.00	99.00				R2-4	K5-A566	3	HINO
623	1	35.00	104.00				R2-4	K5-A567	3	ISUZU
624	5	35.00		148.40	50.00	156.40	R1-2 BB1-2	RUJ-7003	4/9	KOMATSU WITH HOLE IN CROSS
625	1	35.50	119.00				R2-4	K5-A568	3	NISSAN
628	1	36.00	89.00				R2-4	K5-A593	3	WALTERSCHEID
631	1	36.00	97.00				R4-4	K5-A523	3	ISUZU
632	1	36.00	104.00				R2-4	K5-A569	3	MITSUBISHI
634	1	36.00	110.35				R2-4	K5-A571	2	HINO
637	1	36.00	115.60				R2-4	K5-A660	3	HINO
640	2	37.00		71.00			R1-4	RUJ-4009	3	MAZDA
643	2	38.00		62.00			R1-4	RUJ-3005	3	MERCEDES BENZ
646	1	38.00	89.20				R2-4	K5-A675	1	MERCEDES BENZ
649	1	38.00	104.00				R2-4	K5-A572	3	MITSUBISHI
650	1	38.00	104.50		8.00		R2-4	K5-A769	4	GWB 469-30 - OFFSET
651	1	38.00	104.50				R2-4	K5-A781	3	UNIMOG
652	1	38.00	105.80				R2-4	K5-A616	3	DAF
654	1	38.00	106.00				R2-4	K5-A683	4	ELBE 113 SERIES
655	1	38.00	106.00				R2-4	K5-A683HT	4	ELBE 113 HIGH TEMP
656	6	38.00	106.00		42.85	88.90	R2-2 BB2-2	K5-A796	4	ELBE 113 SERIES TO 5C MECH
657	11	38.00	107.00		7.50		R2-4	K5-A763	11/16	ELBE 512 - OFFSET
658	1	38.00	110.00				R2-4	K5-A684	2	MERCEDES BENZ
661	1	38.00	112.00				R2-4	K5-A685	2	186-20 SERIES
664	12	38.00	119.00		9.00		R2-4	K5-A638	1/16	GWB 369-30 - OFFSET
670	1	38.00	148.00				R2-4	K5-A645	2	SCANIA TAPER BRKTS
676	1	38.89	109.60				R2-4	CP55N	3	ROCKWELL
679	1	39.00	116.40				R2-4	K5-A632	2	FIAT TRUCK
680	1	39.00	118.00				R2-4	K5-A831	2	U/J KIT CHINESE BUS
682	1	39.00	127.00				R2-4	K5-A542	3	SCANIA / VOLVO
685	1	39.70	115.90				R2-4	K5-GB22R	2	1510 SERIES
686	1	39.70	115.90				R2-4	K5-A725	3	1630 SERIES HEAVY DUTY
688	7	39.70	115.90				R5-4	K5-GB15R	2	1510 SERIES(Lock Plate)
689	11	40.00	104.30		8.00		R2-4	K5-A823	1	GWB 569.32 STEER AXLE
690	1	40.00	111.00				R2-4	K5-A759	3	MITSUBISHI
691	1	40.00	115.00				R2-4	K5-A639	2	ISUZU
692	1	40.00	115.50				R2-4	K5-A748	3	HINO
694	1	40.00	118.00				R4-4	K5-A573	2	TOYOTA
697	5	40.00		169.20	50.10	180.60	R1-2 BB2-2	RUJ-8001	4/9	KOMATSU WITH HOLE IN CROSS
700	1	41.00	108.00				R2-4	K5-A665	3	T90 PTO
703	1	41.00	118.00				R2-4	K5-A594	3	SERIES 10 PTO
704	5	41.00		110.50	49.21	117.60	R1-2 BB2-2	RUJ-7001	2	FURUKAWA/KOMATSU
706	1	41.28	128.63				R2-4	CP750N-1	3	750N SERIES
707	1	41.28	125.91				R2-4	K5-A782	3	SPL90 SERIES
709	1	41.28	142.00				R2-4	5-165X	2	1650 SERIES
712	6	41.28	142.00		49.21	117.60	R2-2 C3-2	5-331X	2	1650 SERIES TO 7C MECH-2xWING (Thread)
715	6	41.28	142.00		49.21	117.60	R2-2 BB2-2	5-330X	2	1650 SERIES TO 7C MECH - 2xBLOCK (Str)

www.hardyspicer.com.au

Document No:	HSDSCAT
Issue:	15
Issue Date:	03/11/14

This catalogue is the copyright
of Hardy Spicer

UNIVERSAL JOINT KITS

REF #	FIG	C	B1	B2	E	F	BEARING TYPE	PART #	SEE NOTES	DESCRIPTION
718	5	41.28		111.10	49.21	117.60	R1-2 BB2-2	RUJ-7002	2	TOYOTA / TCM KOMATSU / JCB 7R-7C
721	2	41.28		111.10			R1-4	114-7294	2	7R MECH
724	5	41.28		167.87	49.21	174.63	R1-2 BB2-2	114-8014	2	U/J/KIT
726	1	42.00	104.00				R2-4	K5-A595	3	WALTERSCHEID
727	1	42.00	104.50				R2-4	K5-A622	3	GWB 587-15
728	1	42.00	106.00				R2-4	K5-A837	3	ATEGO
729	11	42.00	110.00		7.50		R2-4	K5-A742	4/16	ELBE 513 - OFFSET
730	1	42.00	115.00				R2-4	K5-A753	3	ISUZU
731	1	42.00	117.50				R2-4	K5-A783	3	ELBE 148 SERIES
732	1	42.00	119.40				R2-4	K5-A731	3	GWB 687-35
733	1	42.00	119.40				R2-4	K5-A731-4X	4	GWB 687-35 LUBE IN 4CAPS
734	1	42.00	119.40				R2-4	K5-A731W	3	GWB 687-35
735	1	42.00	123.00				R2-4	K5-A686	3	ELBE 115 SERIES
736	1	42.00	125.00				R4-4	K5-A574	3	ISUZU
739	2	42.00		72.00			R1-4	RUJ-5001	3	MERCEDES BENZ
742	1	43.00	128.00				R4-4	K5-A575	3	NISSAN UD
745	1	43.00	136.00				R4-4	K5-A547	3	NISSAN UD
748	1	44.00	124.80				R2-4	K5-A614	3	DAF / MAN
749	1	44.00	126.00				R2-4	K5-A855	3	HINO INCL.2 x C/CLIP SETS
750	1	44.00	126.20				R2-4	K5-A607	3/6	VOLVO (1610) 300 SERIES
751	1	44.00	129.00				R4-4	K5-A576	3	MITSUBISHI
752	1	44.00	129.00				R2-4	K5-A755	3	MITSUBISHI
753	1	44.00	131.00				R2-4	K5-A784	3	MITSUBISHI
757	1	44.00	149.00				R2-4	K5-A596	3	SCANIA T60 (No Wings)
760	2	44.00		84.00			R1-4	RUJ-5002	3	MERCEDES BENZ
761	2	44.03		120.00			R1-4	K5-A832	2	U/J KIT FOTON
763	1	45.00	120.40				R2-4	K5-A606	3	MERCEDES BENZ
765	11	45.00	125.00		8.00		R2-4	K5-A762	1/16	ELBE 515 - OFFSET
766	1	45.00	131.00				R2-4	K5-A687	3	ELBE
768	1	45.00	152.00				R2-4	K5-A803	18	ELBE 418 SERIES
769	1	45.00	152.00				R2-4	K5-A605	3	ELBE 118 SERIES
770	11	45.50	114.10		10.00		R2-4	K5-A778	1/16	WHEEL JOINT - OFFSET
772	1	46.00	136.00				R4-4	K5-A577	3	ISUZU
775	1	46.00	142.00				R4-4	K5-A578	3	MITSUBISHI
778	1	46.00	148.00				R4-4	K5-A586	3	MITSUBISHI
781	1	47.00	124.00				R4-4	K5-A579	3	HINO
784	1	47.00	130.00				R4-4	K5-A662	3	HINO
787	1	47.00	131.00				R2-4	K5-A617	2	HANOMAG
790	1	47.00	138.00				R4-4	K5-A580	3	HINO
791	1	47.00	140.00				R6-4	K5-A827	2	CHINESE TRUCK & BUS
792	12	47.00	142.00				R2-4	K5-A794	1	GWB 369.40 AXLE JOINT
793	1	47.00	144.10				R4-4	K5-A581	3	HINO
794	6	47.60	135.17		68.00	111.00	R2-2 BB2-2	K5-A814	1	GWB 687-40 TO TELMA / RENAULT
795	1	47.60	135.17				R2-4	K5-A732	3	GWB 687-40
796	1	47.60	135.17				R2-4	K5-A732-4X	4	GWB 687-40 LUBE 4xCAPS
797	1	47.60	135.17				R2-4	K5-A732W	3	GWB 687-40
798	7	47.63	134.94		58.72		R5-4	5-279X	2	1610 SERIES
799	9	47.63	134.94		58.72		R5-2 R2-2	5-674X	2/14	1610 SERIES to 1 1/2 ROUND WITH STRAP KIT
802	1	48.00	116.50				R2-4	K5-A623	3	GWB 587-20
805	1	48.00	126.00				R2-4	K5-A633	3	MERCEDES BENZ/ELBE 158
808	1	48.00	131.20				R2-4	K5-A689	2	KEMPF
810	1	48.00	135.40				R2-4	K5-A793	3	KLEIN 490 SERIES / IVECO
811	1	48.00	145.00				R4-4	K5-A582	3	ISUZU
814	1	48.00	161.00				R2-4	K5-A598	3	SCANIA STR BRKTS
820	1	48.00	161.00				R2-4	K5-A599	3	SCANIA TAPER BRKTS
823	1	49.00	135.00				R5-4	K5-A691	3	FIAT
826	1	49.00	136.00				R2-4	K5-A704	4	SERIES 12 PTO 4 LUBE IN CAP
829	1	49.00	155.00				R4-4	K5-A631	2	FIAT TRUCK
831	1	49.20	154.70				R2-4	K5-A779	3	GWB 687-50 SERIES
832	1	49.21	130.18				R4-4	CP6N	3	CP6N SERIES

www.hardyspicer.com.au

Document No:	HSDSCAT
Issue:	15
Issue Date:	03/11/14

This catalogue is the copyright of Hardy Spicer

UNIVERSAL JOINT KITS

REF #	FIG	C	B1	B2	E	F	BEARING TYPE	PART #	SEE NOTES	DESCRIPTION
835	1	49.21	150.72				R2-4	CP850N-4	3	850N SERIES
838	7	49.21	154.78		61.90		R5-4	5-280X	2	1710 SERIES
841	9	49.21	154.78		61.90		R5-2	5-675X	2/15	1710 SERIES - 1/2 ROUND WITH STRAP KIT
		49.21	157.08				R2-2			
847	8	49.21	154.78		61.90		R5-2	K5-A696	2/15	1710 SERIES to 8.5C MECH
					71.44	123.83	BB2-2			
850	7	49.21	177.80				R5-4	5-407X	2	1760 SERIES
853	9	49.21	177.80		61.90		R5-2	5-677X	2	1760 SERIES to 1/2 ROUND WITH STRAP KIT
		49.21	180.10				R2-2			
856	7	49.21	191.69		61.90		R5-4	5-281X	2	1810 SERIES
859	9	49.21	191.69		61.90		R5-2	5-676X	2/15	1810 SERIES to 1/2 ROUND WITH STRAP KIT
		49.21	194.00				R2-2			
862	8	49.21	191.69		61.90		R5-2	5-324X	2	1810 SERIES TO 9C MECH. MACK TRUCK
					71.44	168.30	BB2-2			
864	1	50.00	118.00				R2-4	K5-A752	3	WALTERSCHEID W2700
865	4	50.00	131.00				R2-4	K5-A692	3	HANOMAG
868	1	50.00	152.60				R2-4	K5-A543	3/6	VOLVO 400 SERIES
871	1	50.00	153.00				R2-4	K5-A636	3	GWB 287-40
873	1	50.00	155.00				R4-4	K5-A754	3	ISUZU
874	1	50.00	159.00				R4-4	K5-A583	2	HINO
877	1	50.00	164.00				R2-4	K5-A597	3	SCANIA T70
880	1	50.00	165.00				R4-4	K5-A659	3	HINO
883	1	50.80	150.83				R4-4	CP7N	2	7N SERIES
884	1	52.00	125.00				R2-4	K5-A780	3	COMER D120 SERIES
885	1	52.00	133.00				R2-4	K5-A619	3	GWB 587-30
886	1	52.00	147.20				R2-4	K5-A722	3	GWB 687-45
887	1	52.00	147.20				R2-4	K5-A722-4X	4	GWB 687-45 LUBE 4xCAPS
888	1	52.00	147.20				R2-4	K5-A722SF	3	GWB 687-45 SERVICE FREE
889	1	52.00	147.20				R2-4	K5-A722W	3	GWB 687-45
890	1	52.00	154.00				R4-4	K5-A584	3	MITSUBISHI
891	1	52.00	160.00				R4-4	K5-A670	3	MITSUBISHI
892	1	52.00	170.00				R4-4	K5-A758	3	MITSUBISHI
893	6	52.32	174.75				R2-2	K5-A813	1	RPL20 SERIES
					71.37	134.62	BB2-2			
894	6	52.32	208.28				R2-2	K5-A806	1	RPL25 SERIES
					71.37	168.40	BB2-2			
895	1	53.00	135.00				R2-4	K5-A658	3	MERCEDES BENZ/ELBE117
896	1	53.50	155.00				R4-4	K5-A786	3	ISUZU
898	1	55.00	164.00				R4-4	K5-A548	3	NISSAN UD
901	1	55.00	164.00				R2-4	K5-A618	3	HANOMAG
902	1	55.00	164.00				R2-4	SPL170X	3	SPL170 SPICER
903	1	55.00	164.00				R2-4	SPL170XW	3	SPL170 SPICER
904	1	55.00	169.00				R4-4	K5-A694	3	ISUZU
907	7	55.55	205.59		71.44		R5-4	5-308X	2	1880 SERIES
910	8	55.55	205.59		71.44		R5-2	5-326X	2	1880 SERIES TO 9C MECH - 2xBLOCK (Str)
					71.44	168.30	BB2-2			
913	8	55.55	205.59		71.44		R5-2	5-327X	2	1880 SERIES TO 9C MECH-xBLOCK(Thread)
					71.44	168.30	BB1-2			
916	1	55.55	205.59				R2-4	5-185X	2	1850 SERIES
919	6	55.55	205.59				R2-2	5-186X	2	1850 SERIES TO 9C MECH - 2xBLOCK (Str)
					71.44	168.30	BB2-2			
924	1	57.00	144.00				R2-4	K5-A624	3	GWB 587-35 / 36
927	1	57.00	152.06				R2-4	K5-A620	2	GWB 587-42 / 687-55
928	1	57.00	152.06				R2-4	K5-A620-4X	4	GWB 587-42 4xLUBE IN CAP
929	1	57.00	152.06				R2-4	K5-A620SF	2	GWB 687-55 SERVICE FREE
930	1	57.00	152.06				R2-4	K5-A620W	2	GWB 587-42 / 687-55
931	1	57.00	152.60				R2-4	K5-A647	3/6	VOLVO 500/600 SERIES
932	1	57.00	152.60				R2-4	K5-A647W	3/6	VOLVO 500/600 SERIES
933	1	57.00	152.06				R2-2	K5-A768	3	SCANIA P500 TAPER BRKTS
		57.00	164.00				R2-2			GWB 687-55 CONVERSION
934	1	57.00	164.00				R2-4	K5-A600	3	SCANIA T71 STR BRKTS
935	1	57.00	164.00				R2-4	K5-A601	3	SCANIA P50 TAPER BRKTS
936	1	57.00	172.00				R2-4	K5-A833	3	KLEIN 680 SERIES
937	1	58.00	175.00				R4-4	K5-A785	3	HINO
938	7	59.00	167.49		71.44		R5-4	5-124X	7	1800 SERIES
939	1	59.00	167.69				R2-4	K5-A733	3	GWB 687-60

www.hardyspicer.com.au

Document No:	HSDSCAT
Issue:	15
Issue Date:	03/11/14

This catalogue is the copyright of Hardy Spicer

UNIVERSAL JOINT KITS

REF #	FIG	C	B1	B2	E	F	BEARING TYPE	PART #	SEE NOTES	DESCRIPTION
940	1	59.00	167.69				R2-4	K5-A733SF	3	GWB 687-60 SERVICE FREE
941	1	60.00	163.00				R2-4	SPL250X	3	SPL250 SERIES
942	1	60.00	163.00				R2-4	SPL250XW	3	SPL250 SERIES
943	1	60.00	163.00				R2-4	SPL250-SF3X	3	SPL250 SERVICE FREE
944	1	60.00	170.00				R4-4	K5-A630	2	FIAT TRUCK
946	1	63.50	178.00				R4-4	K5-A695	2	NISSAN UD
947	1	63.53	196.14				R2-4	CP950N	3	950N SERIES
948	1	65.00	157.00				R2-4	K5-A743	3	VOITH S180.5 SERIES
949	1	65.00	172.00				R2-4	K5-A643	3	GWB 587-48/687-65/ELBE 122
950	1	65.00	172.00				R2-4	K5-A643-4X	4	GWB 587-48 LUBE IN 4 CAPS
951	1	65.00	172.00				R2-4	K5-A643SF	3	GWB 687-65 SERVICE FREE
952	1	65.00	172.00				R2-4	K5-A643W	3	GWB 587-48/687-65/ELBE 122
953	1	65.00	190.00				R2-4	K5-A756	3	SCANIA
954	2	65.00		143.00			R3-4	K5-A634	3	GWB 190-50
955	2	68.00		95.00			R1-4	K5-A775	3	MERCEDES 656
956	2	68.00		123.00			R1-4	K5-A802	3	MERCEDES 659 (385-65)
957	7	68.00	192.00				R5-4	K5-A851	2	BELKARD
958	7	71.43	223.04				R4-4	5-54X	2	1900 SERIES
959	1	72.00	185.00				R2-4	K5-A625	3	GWB 587-50
960	1	72.00	185.00				R2-4	K5-A625W	3/4	GWB 587-50
962	1	72.00	185.00				R2-4	K5-A625-4X	4	GWB 587-50 LUBE IN 4 CAPS
962	4	74.00		129.00			R3-4	K5-A707	2	GWB 292-50 / 392-50
963	4	74.00		129.00			R3-4	K5-A707W	2	GWB 292-50 / 392-50
964	4	74.00		154.00			R3-4	K5-A626	2	GWB 190-55
965	4	74.00		154.00			R3-4	K5-A626W	2	GWB 190-55
968	1	74.00	170.00				R2-4	K5-A789	3	VOITH MT225.8 SERIES
969	1	74.00	170.00				R2-4	K5-A789-4X	4	VOITH MT225.8 Lube in Cap
972	1	74.00	179.90				R2-4	K5-A792	3	VOITH ST250.8 / WT225.8
975	1	74.00	195.00				R2-4	K5-A801	4	KEMPF 104 & 106 SERIES
978	1	74.00	217.00				R2-4	K5-A708	3	GWB 587-55
979	1	74.00	217.00				R2-4	K5-A708-4X	4	GWB 587-55 LUBE IN 4 CAPS
980	1	74.00	217.00				R2-4	K5-A708W	3/4	GWB 587-55
982	7	77.80	255.19				R5-4	5-339XD	2	1950 SERIES
985	4	83.00		129.00			R3-4	K5-A714	2	GWB 390-60
987	4	83.00		139.00			R3-4	K5-A709	2	GWB 292-55 / 392-55
990	4	83.00		150.00			R3-4	K5-A810	3	SDS TYPE 2C
992	4	83.00		175.00			R3-4	K5-A627	2	GWB 190-60
993	4	83.00		175.00			R3-4	K5-A627W	2	GWB 190-60
995	1	83.00	179.90				R2-4	K5-A772	3	VOITH 250.8 SERIES
996	1	83.00	179.90				R2-4	K5-A772-4X	4	VOITH 250.8 4xLUBE IN CAP
998	1	83.00	220.00				R2-4	K5-A737	3	VOITH S250 SERIES
999	1	83.00	220.00				R2-4	K5-A737-4X	4	VOITH S250 4xLUBE IN CAP
1001	1	83.00	231.40				R2-4	K5-A826	3	GWB 587-60 SERIES
1004	1	90.00	192.00				R2-4	K5-A822	4	WUXI SWC225 SERIES
1006	4	91.00		246.00			R3-4	K5-A857	3	UJ KIT NAJICO H250T/P250R
1008	4	95.00		139.00			R3-4	K5-A715	3	GWB 390-65
1009	4	95.00		139.00			R3-4	K5-A715-4X	4	GWB 390-65 4xLUBE IN CAP
1011	4	95.00		160.00			R3-4	K5-A710	2	GWB 292-60 / 392-60
1012	4	95.00		160.00			R3-4	K5-A710-4X	4	GWB 292-60 4xLUBE IN CAP
1015	4	95.00		190.00			R3-4	K5-A628	2	GWB 190-65
1016	4	95.00		190.00			R3-4	K5-A628W	2	GWB 190-65
1017	1	95.00	218.00				R2-4	K5-A849	3	FDILC-250 SERIES
1018	1	95.00	220.00				R2-4	K5-A761	3	VOITH 250.8 SERIES
1019	1	95.00	220.00				R2-4	K5-A761-4X	4	VOITH 250.8 4xLUBE IN CAP
1022	1	95.00	250.00				R2-4	K5-A736	3	VOITH 285.9 SERIES
1023	1	95.00	250.00				R2-4	K5-A736-4X	3	VOITH 285.9 4xLUBE IN CAP
1026	4	110.00		160.00			R3-4	K5-A716	3	GWB 390-70
1028	4	110.00		176.00			R3-4	K5-A711	2	GWB 292-65 / 392-65
1029	4	110.00		176.00			R3-4	K5-A711-4X	4	GWB 292-65 4xLUBE IN CAP
1032	4	110.00		210.00			R3-4	K5-A629	2	GWB 190-70
1035	1	110.00	245.00				R2-4	K5-A818-4X	4	VOITH MT315.8 SERIES
1037	1	110.00	275.00				R2-4	K5-A747	3	VOITH 315.9 SERIES
1038	1	110.00	275.00				R2-4	K5-A747-4X	4	VOITH 315.9 4xLUBE IN CAP
1041	4	120.00		176.00			R3-4	K5-A717	3	GWB 390-75
1042	4	120.00		176.00			R3-4	K5-A717-4X	4	GWB 390-75 4xLUBE IN CAP

www.hardyspicer.com.au

Document No:	HSDSCAT
Issue:	15
Issue Date:	03/11/14

This catalogue is the copyright of Hardy Spicer

UNIVERSAL JOINT KITS

REF #	FIG	C	B1	B2	E	F	BEARING TYPE	PART #	SEE NOTES	DESCRIPTION
1044	4	120.00		196.00			R3-4	K5-A718	3	GWB 292.70 / 392.70
1045	4	120.00		196.00			R3-4	K5-A718-4X	4	GWB 292.70 4xLUBE IN CAP
1048	4	120.00		235.00			R3-4	K5-A712	2	GWB 190-75
1051	4	130.00		196.00			R3-4	K5-A719	3	GWB 390-80 SERIES
1052	4	130.00		196.00			R3-4	K5-A719-4X	4	GWB 390-80 4xLUBE IN CAP
1054	4	130.00		216.00			R3-4	K5-A790	3	GWB 292/392/393.75 SERIES
1057	4	130.00		262.00			R3-4	K5-A713	2	GWB 190-80
1062	4	154.00		250.00			R3-4	K5-A820	3	GWB 292/392/393.80 SERIES
1063	4	154.00		250.00			R3-4	K5-A820-4X	4	GWB 393.80 4xLUBE IN CAP
1067	4	170.00		276.00			R3-4	K5-A791	3	GWB 292/392/393.85 SERIES
1068	4	170.00		276.00			R3-4	K5-A791-4X	4	GWB 393.85 4xLUBE IN CAP
1070	1	175.00	377.00				R2-4	K5-A770	3	VOITH 440.9 SERIES
1072	1	188.00	420.00				R2-4	K5-A807	3	VOITH 490.9 SERIES
1075	4	195.00		315.00			R3-4	K5-A821	3	GWB 292/392/393.90 SERIES
1078	10	13.21			33.34	59.53	C3-4	114-2110	4	2C MECH-4xWING (Thread)
1079	10	13.21			33.34	59.53	C1-2	114-2116	2	2C MECH-2xWING (C/Sunk)
		13.21			33.34	59.53	C3-2			-2xWING (Thread)
1081	10	13.21			33.34	59.53	C1-2	114-2185	4	2C MECH-2xWING(C/Sunk)
		13.21			33.34	59.53	C3-2			-2xWING (Thread)
1083	10	13.21			33.34	59.53	C1-4	114-2117	2	2C MECH-4xWING(C/Sunk)
1085	10	13.21			33.34	59.53	C2-4	RUJ-2046	4	2C MECH-4xWING (Straight)
1086	10	15.50			36.52	69.85	BB2-4	114-3125	4	3C MECH-4xBLOCK (Straight)
1087	10	15.50			36.52	69.85	C3-4	114-3100	2	3C MECH-4xWING (Thread)
1088	10	15.50			36.52	69.85	C1-2	114-3101	2	3C MECH-2xWING(C/Sunk)
		15.50			36.52	69.85	C3-2			-2xWING (Thread)
1089	10	15.50			36.52	69.85	C1-4	114-3103	2	3C MECH-4xWING(C/Sunk)
1091	10	15.50			36.52	87.32	C1-2	RUJ-4003	2	4C MECH-2xWING(C/Sunk)
		15.50			36.52	87.32	C3-2			-2xWING (Thread)
1093	10	15.50			36.52	87.32	C1-2	114-4105	2	4C MECH-2xWING(C/Sunk)
		15.50			36.52	87.32	C2-2			-2xWING (Straight)
1095	10	15.50			36.52	87.32	C3-2	114-4110	2	4C MECH-2xWING (Thread)
		15.50			36.52	87.32	BB2-2			-2xBLOCK(Straight)
1097	10	15.50			36.52	87.32	BB2-4	114-4113	2	4C MECH-4xBLOCK(Straight)
1099	10	15.50			36.52	87.32	C3-4	114-4100	2	4C MECH-4xWING (Thread)
1100	10	15.50			36.52	87.32	C1-2	114-4103	2	4C MECH-2xWING(C/Sunk)
		15.50			36.52	87.32	C3-2			-2xWING (Thread)
1103	10	17.53			42.85	88.90	C3-4	114-5122	2	5C MECH-4xWING (Thread)
1105	10	17.53			42.85	88.90	C2-4	114-5148	2	5C MECH-4xWING (Straight)
1108	10	17.53			42.85	88.90	BB2-4	114-5177	2	5C MECH-4xBLOCK(Straight)
1109	10	17.53			42.85	88.90	BB2-4	114-5177PL	1	5C MECH LUBED For LIFE
1111	10	17.53			42.85	88.90	C1-2	114-5127	2	5C MECH-2xWING(C/Sunk)
		17.53			42.85	88.90	C3-2			-2xWING (Thread)
1114	10	17.53			42.85	88.90	C3-2	114-5173	2	5C MECH-2xWING (Thread)
		17.53			42.85	88.90	BB2-2			-2xBLOCK(Straight)
1116	10	17.53			42.85	88.90	C3-2	114-5031	1/9	5C MECH-2xWING (Thread)
		17.53			42.85	88.90	BB2-2			-2xBLOCK(Straight)
1120	10	17.53			42.85	114.30	C1-2	114-6104	2	6C MECH-4xWING(C/Sunk)
1123	10	17.53			42.85	114.30	BB2-4	114-6128	2	6C MECH-4xBLOCK(Straight)
1124	10	17.53			42.85	114.30	BB2-4	114-6128PL	1	6C MECH LUBED For LIFE
1125	10	17.53			42.85	114.30	BB2-4	114-6128R	2	6C MECH PREMIUM
1127	10	17.53			42.85	114.30	C3-4	114-6143	2	6C MECH-4xWING (Thread)
1128	10	17.53			42.85	114.30	C3-4	114-6143R	2	6C MECH PREMIUM
1130	10	17.53			42.85	114.30	C2-2	114-6103	2	6C MECH-2xWING (Straight)
		17.53			42.85	114.30	C3-2			-2xWING (Thread)
1132	10	17.53			42.85	114.30	C3-2	114-6114	2	6C MECH-2xWING (Thread)
		17.53			42.85	114.30	BB2-2			-2xBLOCK(Straight)
1133	10	17.53			42.85	114.30	C3-2	114-6114R	2	6C MECH PREMIUM
		17.53			42.85	114.30	BB2-2			2xWING (Thrd)-2xBLOCK(Str)
1136	10	17.53			42.85	114.30	C2-2	114-6152	2	6C MECH-2xWING (Straight)
		17.53			42.85	114.30	C3-2			-2xWING (Thread)
1138	10	17.53			42.85	114.30	BB2-2	114-6285	2	6C MECH-2xBLOCK(Straight)
		17.53			42.85	114.30	BB3-2			-2xDbI. Sided Block
1140	10	17.53			42.85	114.30	C3-2	114-6162	2	6C MECH-4xWING (Thread)
		20.57			49.21	117.60	C3-2			TO 7C MECH
1143	10	17.53			42.85	114.30	C3-2	114-6163	2	6C MECH-2xWING (Thread)
		20.57			49.21	117.60	BB2-2			TO 7C MECH-2xBLOCK (Str.)

www.hardyspicer.com.au

Document No:	HSDSCAT
Issue:	15
Issue Date:	03/11/14

This catalogue is the copyright of Hardy Spicer

UNIVERSAL JOINT KITS

REF #	FIG	C	B1	B2	E	F	BEARING TYPE	PART #	SEE NOTES	DESCRIPTION
1144	10	17.53 20.57			42.85 49.21	114.30 117.60	BB2-2 C3-2	114-6164	2	6C MECH-2xBLOCK (Str) TO 7C MECH-2xWing(Thread)
1146	10	17.53 20.57			42.85 49.21	114.30 117.60	BB2-2 BB2-2	114-6166	2	6C MECH-2xBLOCK (Str) TO 7C MECH-2xBLOCK (Str.)
1148	10				46.00	108.00	BB2-4	RUJ-6069	2	TCM
1150	10				49.20	104.00	BB2-4	114-7295	3	DEUTZ Tractor-4xBLOCK(Str.)
1152	10	20.57			49.21	107.50	C3-4	CP58WB-29	2	ROCKWELL-4xWing(Thrd.)
1154	10	20.57			49.21	107.50	BB2-4	CP58WB-38	2	ROCKWELL- 4xBLOCK (Str.)
1156	10	20.57			49.21 49.21	107.50 107.50	C3-2 BB2-2	CP58WB-37	2	ROCKWELL-2xWing(Thrd.)
1158	10	20.57			49.21	117.60	BB2-4	114-7273	2	7CMECH 4xLUBE IN CROSS
1162	10	20.57			49.21	117.60	BB2-4	114-7126	2	7CMECH4xBLOCK(Straight)
1163	10	20.57			49.21	117.60	BB2-4	114-7126PL	1	7C MECH LUBED For LIFE
1164	10	20.57			49.21	117.60	BB2-4	114-7126R	1	7C MECH PREMIUM
1167	10	20.57			49.21	117.60	C3-4	114-7205	2	7C MECH-4xWING (Thread)
1168	10	20.57			49.21	117.60	C3-4	114-7205R	2	7C MECH PREMIUM
1170	10	20.57			49.21	117.60	C1-4	114-7208	2	7C MECH-4xWing(C/Sunk)
1172	10	20.57 20.57			49.21 49.21	117.60 117.60	C3-2 BB2-2	114-7207	2	7C MECH-2xWING(Thread) -2xBLOCK (Str)
1173	10	20.57 20.57			49.21 49.21	117.60 117.60	C3-2 BB2-2	114-7207R	2	7C MECH PREMIUM 2xWING(Thrd)-2xBLOCK(Str)
1175	10	20.57 20.57			49.21 49.21	117.60 117.60	C1-2 C3-2	114-7206	2	7C MECH-2xWing (C/Sunk) -2xWING (Thread)
1177	10	20.57 20.57			49.21 49.21	117.60 117.60	C1-2 BB2-2	114-7209	2	7C MECH-2xWING(C/Sunk) -2xBLOCK(Straight)
1180	10	20.57			49.21	174.63	BB2-4	114-8113	2	8C MECH-4xBLOCK(Str)
1181	10	20.57			49.21	174.63	BB2-4	114-8113PL	1	8C MECH LUBE FOR LIFE
1182	10	20.57			49.21	174.63	BB2-4	114-8113R	1	8C MECH PREMIUM
1185	10	20.57			49.21	174.63	C3-4	114-8205	2	8C MECH-4xWING (Thread)
1186	10	20.57			49.21	174.63	C3-4	114-8205R	2	8C MECH PREMIUM
1188	10	20.57 20.57			49.21 49.21	174.63 174.63	C1-2 C3-2	114-8206	2	8C MECH-2xWING(C/Sunk) -2xWING (Thread)
1190	10	20.57 20.57			49.21 49.21	174.63 174.63	C3-2 BB2-2	114-8207	2	8C MECH-2xWING (Thread) -2xBLOCK (Str)
1191	10	20.57 20.57			49.21 49.21	174.63 174.63	C3-2 BB2-2	114-8207R	2	8C MECH PREMIUM 2xWING (Thr)-2xBLOCK (Str)
1193	10				50.00	115.00	C3-4	RUJ-7000	2	ISUZU - 4xWING (Thread)
1195	10				50.10	180.60	BB2-4	RUJ-8002	4/9	KOMATSU-4xBLOCK(STR)
1198	10				56.00	140.00	C3-4	114-8209	2	ISUZU - 4xWING (Thread)
1200	10				60.00	104.00	BB2-4	114-8210	2	FURUKAWA-4xBLOCK(Str)
1202	10	23.50			60.00	146.00	BB2-4	RUJ-9902	2	UG 990 SERIES
1205	10				60.10	159.00	C3-4	RUJ-8003	3	U/J KIT
1207	10	23.37			61.98	125.22	BB2-4	114-8211	2	J170 - 4xBLOCK (Straight)
1210	10	28.50			70.00	168.00	BB2-4	RUJ-91110	2	UG 1110 SERIES
1212	10	25.40			71.44	123.83	BB2-4	114-8516	2	8.5C MECH-4xBLOCK (Str)
1213	10	25.40			71.44	123.83	BB2-4	114-8516PL	1	8-5C MECH Lube For Life
1214	10	25.40			71.44	123.83	BB2-4	114-8516R	3	8-5C MECH PREMIUM
1217	10	25.40			71.44	123.83	C3-4	114-8514	2	8-5C MECH-4xWING(Thread)
1219	10	25.40 25.40			71.44 71.44	123.83 123.83	C3-2 BB2-2	114-8508	2	8-5C MECH-2xWING(Thread) -2xBLOCK (Str.)
1220	10	25.40 25.40			71.44 71.44	123.83 123.83	C3-2 BB2-2	114-8508R	2	8-5C MECH PREMIUM 2xWING(Thrd)-2xBLOCK (Str.)
1222	10	25.40			71.44	168.30	C3-4	114-9014HD	1	9C MECH-4xWING (Thread)
1223	10	25.40			71.44	168.30	C3-4	114-9014R	1	9C MECH PREMIUM
1226	10	25.40			71.44	168.30	C1-4	114-9015	2	9C MECH-4xWing(C/Sunk)
1228	10	25.40			71.44	168.30	BB2-4	114-9016	2	9C MECH - 4xBLOCK (Str.)
1229	10	25.40			71.44	168.30	BB2-4	114-9016PL	1	9C MECH LUBE FOR LIFE
1230	10	25.40			71.44	168.30	BB2-4	114-9016R	1	9C MECH PREMIUM
1232	10	25.40			71.44	168.30	BB2-4	114-9038	3	9C MECH - CENTRE LUBE
1233	10	25.40 25.40			71.44 71.44	168.30 168.30	C3-2 BB2-2	114-9017	2	9C MECH-2xWING (Thread) -2xBLOCK (Straight)
1234	10	25.40 25.40			71.44 71.44	168.30 168.30	C3-2 BB2-2	114-9017R	2	9C MECH PREMIUM 2xWING (Thrd)-2xBLOCK(Str)
1236	10	25.40 25.40			71.44 71.44	168.30 168.30	C1-2 C3-2	114-9026	2	9C MECH-2xWING (C/Sunk) -2xWING (Thread)
1239	10	28.19			71.44	168.30	BB2-4	114-9500	1	9.5C/J310 - 4xBLOCK (Str.)

www.hardyspicer.com.au

Document No:	HSDSCAT
Issue:	15
Issue Date:	03/11/14

This catalogue is the copyright of Hardy Spicer

UNIVERSAL JOINT KITS

REF #	FIG	C	B1	B2	E	F	BEARING TYPE	PART #	SEE NOTES	DESCRIPTION
1242	10	32.50			82.00	198.00	BB2-4	RUJ-11500	2	ICUG 11.5C SERIES
1245	10	34.00			88.90	172.72	BB2-4	RUJ-11000	2	KOMATSU
1248	10	34.04			88.90	172.72	BB2-4	114-10500	2	10.5C/J490-4xBLOCK (Str.) .625" BOLTS
1251	10	40.13			88.90	172.72	BB2-4	114-11002	2	11C/J600-4xBLOCK(Str) .750" BOLTS
1254	10	34.04 32.51			88.90 92.07	172.72 165.10	BB2-4	114-10033	2	J490 TO 10C MECH (.625 BOLT) - 4xBlock(Str.)
1256	10	32.51			92.07	165.10	BB2-4	114-10003	2/7	10C MECH (.562 BOLT) -4xBLOCK(Straight)
1259	10	32.51			92.07	165.10	C1-4	114-10007	2	10C MECH-4xWing(C/Sunk)
1261	10	32.51			92.07	165.10	BB2-4	114-10011	2/8	10C MECH (.625 BOLT) -4xBLOCK (Straight)
1262	10	32.51			92.07	165.10	BB2-4	114-10011PL	1/8	10C MECH LUBE FOR LIFE 5/8" Bolt-4xBLOCK (Straight)
1264	10	38.00			92.00	227.00	BB2-4	RUJ-12500	2	TEREX
1266	10	32.51			92.20	241.30	BB2-4	114-12002	2	KOMATSU (14mm BOLT) -4xBLOCK (Straight)
1267	10	32.51			92.20	241.30	BB2-4	114-12002HD	2	KOMATSU (14mm BOLT) -4xBLOCK (Straight)
1269	10	38.10			99.97	199.95	BB2-4	114-15002	2	15C/J800 - 4xBLOCK (Str)
1270	10	38.10			99.97	199.95	BB2-4	114-15002W	2	15C/J800 - 4xBLOCK (Str)
1271	10	38.10			99.97	199.95	BB2-4	114-15002PL	1	15C MECH-LUBE FOR LIFE
1272	10	38.10			99.97	199.95	BB2-4	114-15003	1	15C MECH-METRIC BOLTS
1273	10	38.10			99.97	199.95	BB2-4	114-15003PL	1	15C MECH-LUBE FOR LIFE
1274	10	38.10			99.97	199.95	BB2-4	114-15500PL	1	15-5C MECH-LUBE FOR LIFE
1277	10	44.00			107.00	252.00	BB2-4	RUJ-14500	2	14-5C SERIES
1280	10				135.00	270.00	BB2-4	RUJ-14001	2	KOMATSU HIGH SPEED

www.hardyspicer.com.au

Document No:	HSDSCAT
Issue:	15
Issue Date:	03/11/14

This catalogue is the copyright
of Hardy Spicer

UNIVERSAL JOINT KITS

CIRCLIPS

Diameter	Thickness	Part Number	Suit
23.80	.058"	<i>SR-2380-058</i>	1140
23.80	.060"	<i>SR-2380-060</i>	1140
23.80	.061"	<i>SR-2380-061</i>	1140
23.80	.063"	<i>SR-2380-063</i>	1140
27.00	.058	<i>SR-2700-058</i>	1310/1330/687.15
27.00	.060"	<i>SR-2700-060</i>	1310/1330/687.15
27.00	.061"	<i>SR-2700-061</i>	1310/1330/687.15
27.00	.062"	<i>SR-2700-062</i>	1310/1330/687.15
27.00	.063"	<i>SR-2700-063</i>	1310/1330/687.15
27.00	.065"	<i>SR-2700-065</i>	1310/1330/687.15
30.16	.058"	<i>SR-3016-058</i>	1350/1410/687.20
30.16	.060"	<i>SR-3016-060</i>	1350/1410/687.20
30.16	.061"	<i>SR-3016-061</i>	1350/1410/687.20
30.16	.063"	<i>SR-3016-063</i>	1350/1410/687.20
30.16	.065"	<i>SR-3016-065</i>	1350/1410/687.20
34.93	.061"	<i>SR-3493-061</i>	1480/1550/687.25/30
34.93	.063"	<i>SR-3493-063</i>	1480/1550/687.25/30
34.93	.065"	<i>SR-3493-065</i>	1480/1550/687.25/30
34.93	.067"	<i>SR-3493-067</i>	1480/1550/687.25/30
34.93	.071"	<i>SR-3493-071</i>	1480/1550/687.25/30
34.93	.073"	<i>SR-3493-073</i>	1480/1550/687.25/30
39.70	.071"	<i>SR-3970-071</i>	1510/1630
42.00	1.80mm	<i>SR-4200-1800M</i>	587.15/687.35
48.00	1.75mm	<i>SR-4800-1750M</i>	587.20/687.40
48.00	1.80mm	<i>SR-4800-1800M</i>	587.20/687.40
48.00	2.05mm	<i>SR-4800-2050M</i>	587.20/687.40
52.00	2.15mm	<i>SR-5200-2150M</i>	587.30/687.45
57.00	2.175mm	<i>SR-5700-2175M</i>	587.35/36/42/687.55
57.00	2.35mm	<i>SR-5700-2350M</i>	587.35/36/42/687.55
59.00	2.20mm	<i>SR-5900-2200M</i>	687.60
65.00	2.85mm	<i>SR-6500-2850M</i>	587.48/687.65
65.00	3.00mm	<i>SR-6500-3000M</i>	587.48/687.65
72.00	2.75mm	<i>SR-7200-2750M</i>	587.50
72.00	3.00mm	<i>SR-7200-3000M</i>	587.50
74.00	2.50mm	<i>SR-7400-2500M</i>	587.55
74.00	2.65mm	<i>SR-7400-2650M</i>	587.55
74.00	3.00mm	<i>SR-7400-3000M</i>	587.55



Diameter	Thickness	Part Number	Suit
29.00	1.6mm	<i>ISR-2900-1.6</i>	RUJ-2100
29.00	1.7mm	<i>ISR-2900-1.7</i>	RUJ-2100



www.hardyspicer.com.au

Document No:	HSDSCAT
Issue:	15
Issue Date:	03/11/14

UNIVERSAL JOINT KITS MIDSHIP NUTS & TORQUE SPECIFICATIONS

PART No.	BOLT or NUT	WASHER PART #	TO SUIT	THREAD	TORQUE
94-GB2201	Nut	510-2400		3/4"-20UNF	205-230Nm 150-170 ft/lbs
509-33	Nut			1"-20UNEF	373-440Nm 275-325 ft/lbs
231502	Nut	510-27	1610 1710-1810	1.250"-18UNEF	644-712Nm 475-525 ft/lbs
20-74-91	Nut FLANGED	Not Required	1610 1710-1810	1.250"-18UNEF	644-712Nm 475-525 ft/lbs
539-001	Bolt		1480-1550	5/8"-18UNF	162-176Nm 120-130 ft/lbs
VOL-23222	Nut	VOL-23223	Volvo	M40 x 1.5mm	1000Nm 737 ft/lbs
VOL-24152	Nut	-	Volvo	M60 x 2.0mm	1000Nm 737 ft/lbs
SC-94-373	Nut	-	Scania	M44 x 1.5mm	600Nm 442 ft/lbs
SC-74-788	Nut	-	Scania	M50 x 1.5mm	600Nm 442 ft/lbs
1-000-008102066	Nut	-	687.15/20 287.20 587.10/15	M27 x 1.5mm	550Nm 406 ft/lbs
1-000-008102067	Nut	-	587.20/30/35 687.40/45 Mercedes Volvo	M40 x 1.5mm	650Nm 479 ft/lbs
1-000-008102073	Nut	-	587.42/48	M45 x 1.5mm	680Nm 502 ft/lbs

www.hardyspicer.com.au

Document No:	HSDSCAT
Issue:	15
Issue Date:	03/11/14

This catalogue is the copyright of Hardy Spicer

UNIVERSAL JOINT KITS HARDWARE TORQUE SPECIFICATIONS

SERIES	BRG DIA.	U-JOINT KIT PART No	U-BOLT or BOLT PART No	LOCK PLATE PART No	THREAD SIZE	TORQUE	or STRAP KIT PART No	THREAD SIZE	TORQUE
U-BOLT or STRAP STYLE									
1310/1330 GM	27.00 1.063	K5-13XR RUJ-3002	102		0.312-24	19-23Nm 14-17ft/lbs	107	0.312-24	34-41Nm 25-30ft/lbs
1310/1330 SPICER	27.00 1.063	K5-13XR RUJ-3002	102		0.312-24	19-23Nm 14-17ft/lbs	2-70-18X	0.250-28	17-24Nm 13-18ft/lbs
1350	30.17 1.188	5-178X	103		0.375-24	27-33Nm 20-24ft/lbs	3-70-28X	0.312-24	34-41Nm 25-30ft/lbs
1410	30.17 1.188	K5-GB10R	103		0.375-24	27-33Nm 20-24ft/lbs	3-70-28X	0.312-24	34-41Nm 25-30ft/lbs
1480	34.92 1.375	5-188X	109		0.437-20	43-50Nm 32-37ft/lbs	3-70-38X	0.375-24	75-81Nm 55-60ft/lbs
1550	34.92 1.375	5-155X	109		0.437-20	43-50Nm 32-37ft/lbs	3-70-38X	0.375-24	75-81Nm 55-60ft/lbs
TWO BEARING PLATE & TWO STRAP STYLE									
1610	47.62 1.875	5-674X	508-45	94-A764			5-70-28X	0.375-24	75-81Nm 55-60ft/lbs
1710	49.20 1.937	5-675X	508-25	94-A339			6.5-70-18X	0.500-20	176-183Nm 130-135ft/lbs
1760	49.20 1.937	5-677X	508-25	94-A339			6.5-70-18X	0.500-20	176-183Nm 130-135ft/lbs
1810	49.20 1.937	5-676X	508-25	94-A339			6.5-70-18X	0.500-20	176-183Nm 130-135ft/lbs
SPL170	55.00 1.165	SPL170X		211941X Spring Tab Kit	M8x1.0	35-40Nm 25-30ft/lbs	170-70-18X	M12x1.25	155-183Nm 115-135ft/lbs
SPL250	60.00 2.362	SPL250X		211941X Spring Tab Kit	M8x1.0	35-40Nm 25-30ft/lbs	250-70-18X	M12x1.25	155-183Nm 115-135ft/lbs
FOUR BEARING PLATE STYLE									
1610	47.62 1.875	5-279X	508-45	94-A764		23-33Nm 17-24ft/lbs			
1610 UK Type	47.62 1.875	5-279X	508-64	94-A764	0.312" BSF	30-37Nm 22-27ft/lbs			
1710	49.20 1.937	5-280X	508-25	94-A339		43-57Nm 32-42ft/lbs			
1710 UK Type	49.20 1.937	5-280X	508-64	94-A339	0.312" BSF	30-37Nm 22-27ft/lbs			
1760	49.20 1.937	5-407X	508-25	94-A339		43-57Nm 32-42ft/lbs			
1810	49.20 1.937	5-281X	508-25	94-A339		43-57Nm 32-42ft/lbs			
1880	55.55 2.187	5-308X	7-73-115#	231009#		68-89Nm 50-66ft/lbs			
MERITOR RPL SERIES									
RPL20		K5-A813	CSC8-20-52		1/2"-20NF	115-135Nm 155-183ft/lbs			
RPL25		K5-A806	CSC8-20-52		1/2"-20NF	115-135Nm 155-183ft/lbs			

To help ensure universal joint retention, it is imperative that the correct cap-screw be used and properly torqued. All must be Grade 8 or equivalent quality. The torque settings apply only to clean, dry, non-coated bolts.

www.hardyspicer.com.au

Document No:	HSDSCAT
Issue:	15
Issue Date:	03/11/14

INDENT ONLY

UNIVERSAL JOINT KITS

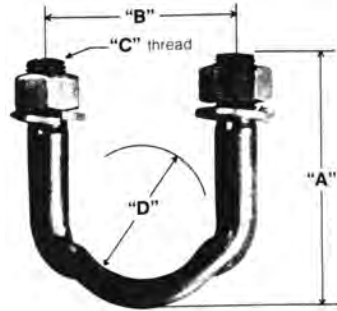
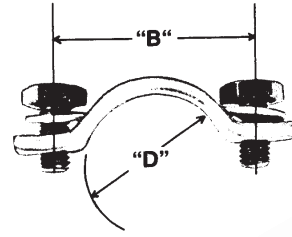

Fig 1



"C" = Hex Head Cap Screw Size

Fig 2



Fig 3

UNIVERSAL JOINT HARDWARE KITS

PART No.	FIG	U-BOLTS or CLAMPS	LOCK WASHER	HEX NUT or CAP SCREW	A	B	C	D	SUITS SHAFT SERIES
102	1	2	4	4	47.62 1.875	35.72 1.106	5/16-24UNF	26.99 1.038	1310 / 1330 1-1/16 CAPS
103UBOLTKIT	1	2	4	4	55.56 2.187	42.07 1.656	3/8-24UNF	30.16 1.187	1350 / 1410
104	1	2	4	4	47.62 1.875	34.92 1.375	1/4-28UNF	25.40 1.000	17R
105	1	2	4	4	50.00 1.969	40.48 1.594	5/16-18UNC	28.57 1.125	1310 / 1330 1-1/8 CAPS
106	2	2	4	4		38.10 1.500	1/4-28	27.38 1.078	21R
107	2	2	4	4		40.48 1.594	5/16-24	26.99 1.038	1310 / 1330 1-1/16 CAPS GM
108	2	2	4	4		46.04 1.812	5/16-24	28.57 1.125	3R
109	1	2	4	4	61.12 2.406	48.42 1.906	7/16-20UNF	34.92 1.375	1480 / 1550
2R-94-10	1	2	4	4	60.32 2.375	34.92 1.375	1/4-28UNF	25.40 1.000	2R
25R-94-11	1	2	4	4	62.00 2.441	39.70 1.562	5/16-24UNF	28.58 1.125	25R
2-70-18X	2	2	4	4		40.48 1.594	1/4-28	26.99 1.038	1310 / 1330 1-1/16 CAPS SPICER
3-70-28X	2	2	4	4		45.87 1.806	5/16-24	30.16 1.187	1350 / 1410 1-3/16 CAPS
3-70-28X-GM	2	2	4	4		42.50 1.674	5/16-24NF 7/16" HEX	30.16 1.187	1350 GM ONLY BOLTS - 1.375" LONG
3-70-38X	2	2	4	4		54.10 2.130	3/8-24	34.92 1.375	1480/1550 1-3/8 CAPS
5-70-28X	2	2	4	4		63.50 2.500	3/8-24	47.62 1.875	1610 1-7/8 CAPS
6-5-70-18X	2	2	4	4		71.27 2.806	1/2-20	49.20 1.937	1710/160/1810 1-15/16 CAPS
170-70-18X	3	2		4		82.00 3.228	M12x1.25	55.00 2.165	SPL170
250-70-18X	3	2		4		87.48 3.444	M12x1.25	60.00 2.362	SPL250

www.hardyspicer.com.au

Document No:	HSDSCAT
Issue:	15
Issue Date:	03/11/14

This catalogue is the copyright
of Hardy Spicer

UNIVERSAL JOINT KITS

JOINT THREAD TORQUE SETTINGS

SIZE	SIZE	ft / lbs	Nm	Notes
2C	5/16 - 24	22 - 27	29.8 - 36.6	
3C	5/16 - 24	22 - 27	29.8 - 36.6	
4C	5/16 - 24	22 - 27	29.8 - 36.6	
5C	3/8 - 24	37 - 49	50.2 - 66.4	
6C	3/8 - 24	37 - 49	50.2 - 66.4	
7C	7/16 - 20	65 - 75	88.1 - 101.7	
7C	1/2 - 20	70 - 80	94.9 - 108.5	
8C	7/16 - 20	65 - 75	88.1 - 101.7	
8C	1/2 - 20	70 - 80	94.9 - 108.5	
8.5C	1/2 - 20	110 - 120	149.1 - 162.7	
9C	M12x1.75	67 - 79	91.0 - 108.0	
9C	1/2 - 20	110 - 120	149.1 - 162.7	
9.5C	1/2 - 20	90 - 110	122.0 - 149.1	
10C	M16x2	164 - 195	223.0 - 265.0	
10C	5/8 - 18	230 - 240	311.8 - 325.4	
10.5C	5/8 - 18	230 - 240	311.8 - 325.4	
11C	M20x2.5	321 - 382	436.0 - 518.0	
11C	3/4 - 16	315 - 345	427.1 - 467.7	
12C	M14x1.5	112 - 134	153.0 - 182.0	
14C	M18x1.5	248 - 295	337.0 - 400.0	
14.5C	M22x1.5	463 - 550	628.0 - 746.0	
15C	M20x2.5	321 - 382	436.0 - 518.0	
15C	3/4 - 16	315 - 345	427.1 - 467.7	

GREASE NIPPLES / RELIEF VALVES

Image	Part Number	Angle	Size	Comments
	94-A588	STR	6mm Self Tapping	
	94-A589	STR	3/16" UNF	
	94-A675	STR	6mm x 0.5mm	5-433-1X U/Joint
	47200B	STR	1/8" BSP	Relief Valve
	1-000-008601003	STR	M10 x 1mm	
	1-000-008601009	90	M10 x 1mm	
	1-000-008601077	TEE	M10 x 1mm	
	1-000-008601125	TEE	M16 x 1.5mm	Combination Grease / Relief H=33
	1-000-008601127	TEE	M16 x 1.5mm	Combination Grease / Relief H=45

www.hardyspicer.com.au





Document No:	HSDSCAT
Issue:	15
Issue Date:	03/11/14

HARDY SPICER CENTRE BEARINGS

AUDI

Vehicle	Model	Hardy Spicer Part No.	O.E.Part No.	Year	Bearing ID	Bolt Hole Centres
AUDI Some models	BEARING AND RUBBER 	AUDI-30-9160			30mm	

BMW

Vehicle	Model	Hardy Spicer Part No.	O.E.Part No.	Year	Bearing ID	Bolt Hole Centres
BMW E30, E32, E34		BM-30-5710	26 11 1 226 723	82-95	30mm	130mm
BMW E21		BM-30-5690	26 11 1 206 502		30mm	135mm
BMW E30		BM-30-5700	26 12 1 225 152	82-93	30mm	140mm
BMW E36, E46	42mm Centre Height 	BM-30-5720	26 12 1 226 731	90-98	30mm	160mm
BMW E38, E39	46mm Centre Height 	BM-30-5730	26 12 1 229 242		30mm	160mm

www.hardyspicer.com.au

Document No:	HSDSCAT
Issue:	15
Issue Date:	03/11/14

This catalogue is the copyright of Hardy Spicer

Caterpillar

Vehicle	Model	Hardy Spicer Part No.	O.E.Part No.	Year	Bearing ID	Bolt Hole Centres
Caterpillar Loader	64mm wide bearing 69mm centre height 	CAT-30-9168	618531		2-7/16" (61.91mm)	187mm

Chevrolet

Vehicle	Model	Hardy Spicer Part No.	O.E.Part No.	Year	Bearing ID	Bolt Hole Centres
GMC	Stalk type centre bearing 	210527X			30mm	38.1mm

Chrysler

Vehicle	Model	Hardy Spicer Part No.	O.E.Part No.	Year	Bearing ID	Bolt Hole Centres
300C		CH-30-7180			30mm	188mm

Daihatsu

Vehicle	Model	Hardy Spicer Part No.	O.E.Part No.	Year	Bearing ID	Bolt Hole Centres
Delta	V12. V22. V32. 	DA-30-3810	37208-87302	77-	35mm	119mm

www.hardyspicer.com.au

Document No:	HSDSCAT
Issue:	15
Issue Date:	03/11/14

Ford						
Vehicle	Model	Hardy Spicer Part No.	O.E.Part No.	Year	Bearing ID	Bolt Hole Centres
Escort, Cortina	 Bearing & Rubber	17R-30-1110			30mm	
Falcon BA, BF Series I only XR6T & XR8 & Some V8	6 CYL Sedans Sedan & Ute with centre u/joint 	FD-30-5830		10/02-	30mm	214mm
Falcon BA, BF Series I only XR6T, XR8	V8 Sedans (with centre CVJ) Sedan & Ute (with centre CVJ) 	FD-30-5835		2004-	35mm	214mm
Falcon BA - BF Rubber and Bearing only Territory SX, SY	6 CYL Sedans Sedan & Ute with centre u/joint 	FD-30-5840		10/02- 5/04-4/09	30mm	N/A
Falcon BA - BF Rubber and Bearing only	V8 Sedans (with centre CVJ) Sedan & Ute (with centre CVJ) 	FD-30-5845		2004-	35mm	N/A
Falcon BF	6 CYL Sedans Sedan & Ute with centre u/joint 	FD-30-5850	BAF4800A		30mm	170mm
Falcon BF	V8 Sedans (with centre CVJ) Sedan & Ute (with centre CVJ) 	FD-30-5855			35mm	170mm

www.hardyspicer.com.au

Document No:	HSDSCAT
Issue:	15
Issue Date:	03/11/14

This catalogue is the copyright of Hardy Spicer

Ford cont.

Vehicle	Model	Hardy Spicer Part No.	O.E.Part No.	Year	Bearing ID	Bolt Hole Centres
Falcon FG	25mm offset centre height 	FD-30-5860			30mm	170mm
Falcon FG	25mm offset centre height 	FD-30-5865			35mm	170mm
Falcon FG	11mm offset centre height 	FD-30-5870			30mm	170mm
Falcon FG	11mm offset centre height 	FD-30-5875			35mm	170mm
Courier Early with 25mm Bearing	Suits Petrol & Diesel 	MZ-30-4310	P027-25-310A P030-25-310A	85-	25mm	165mm
Courier	Carby Models 	MZ-30-4910	P045-25-310	85-89	28mm	170mm
Courier	2WD EFI Models 	MZ-30-5780	P047-25-310A	-1/99	28mm	164mm
Courier	4WD Models 	MZ-30-5680	P065-25-310A	-1/99	28mm	180mm
Courier	2WD Models EFI & DIESEL 	MZ-30-6900	SA02-25-100	2/99-	28mm	161mm

www.hardyspicer.com.au

Document No:	HSDSCAT
Issue:	15
Issue Date:	03/11/14

This catalogue is the copyright of Hardy Spicer

Ford cont.

Vehicle	Model	Hardy Spicer Part No.	O.E.Part No.	Year	Bearing ID	Bolt Hole Centres
Courier (EXCEPT V6)	4WD Models 	MZ-30-6910	SA54-25-100	2/99-	28mm	180mm
Ranger 2WD	2.5L DT PJ-PK 	FD-30-7030	SA02-25-300	11/06-10/11	35mm	164mm
Ranger 2WD Ranger 4WD	3.0DT PJ-PK MAN 3.0DT AUTO 3.0DT 	FD-30-7040	SA68-25-300A	11/06-10/11 11/06-10/11 11/06-8/08	35mm	180mm
Escape	AUTO V6 3.0L 	FD-30-6970		11/06-10/11	30mm	175mm
Transit	VE 	FD-30-5210 FD-30-5245 FD-30-5195	95VB-4826-AA 8C114826 AA	8/94- LATE Staked UJ	30mm 45mm 35mm 14mm Wide	144mm 146mm 144mm
Trader		MZ-30-5590			35mm	180mm
F100 F150 Some F250 Check Brg ID		211187X			35mm	168mm
F250		210866X			40mm	168mm

www.hardyspicer.com.au

Document No:	HSDSCAT
Issue:	15
Issue Date:	03/11/14

This catalogue is the copyright of Hardy Spicer

Great Wall

Vehicle	Model	Hardy Spicer Part No.	O.E.Part No.	Year	Bearing ID	Bolt Hole Centres
Great Wall	 (Centre to Mounting flange 85mm)	IS-30-4110			30mm	94mm

GWB / European

Hardy Spicer Part No.	Model	Centre Height	O.E.Part No.	Bearing Width	Bearing ID	Bolt Hole Centres
211447X	 687-30/35 IVECO	68.3mm		19mm	45mm	194mm
6-613-550199000	 687-20	71.5mm		18mm	55mm	168mm
6-387-300127080	 587-20/30 IVECO MAN DAF	71.5mm		36.6mm	55mm	200mm
6-613-550100560	 687-35/40/45 VOLVO, DAF Re-lube Solid Rubber	69.1mm		18mm	55mm	200mm
6-613-550100690	 687-35/40/45 VOLVO	71.5mm		18mm	55mm	200mm
6-613-600100070	 687-30 Reverse Slip			19mm	60mm	194mm
6-187-400100010	 587-35/36 687-45/55 IVECO/MAN SPL250 Sealed Brg Small Slingers	80mm		36.6mm	60mm	200mm
211402X	 687-45/55 RENAULT SPL250 Large Slingers	80mm		36mm	60mm	200mm

www.hardyspicer.com.au

Document No:	HSDSCAT
Issue:	15
Issue Date:	03/11/14

GWB / European							
Hardy Spicer Part No.	Model	Centre Height	O.E.Part No.	Bearing Width	Bearing ID	Bolt Hole Centres	
6-613-6501AU650	587-42 MAN Solid Rubber 	85.8mm		23mm	65mm	225mm	
6-113-650111010	587-42 MAN 	85.8mm		23mm	65mm	230mm	
6-613-700100030	687-55/60/65 Fluted Rubber Standard 	85.8mm		20mm	70mm	220mm	
6-113-700127190	687-55/60/65 DAF, Iveco Soft Solid Rubber Reinforced Bolt Holes 	85.8mm		20mm	70mm	220mm	
6-113-700184060	687-55/60/65, DAF Solid Rubber 	85.8mm		20mm	70mm	220mm	
126-700-10202	Cast Bracket Iveco 	88mm		43mm	70mm	220mm Ø15mm	
126-700-11724	Cast Bracket Klein 700, DAF 	88mm		43mm	70mm	220mm Ø15mm 30mm Slots	
6-613-750100090	IVECO, MAN 	90mm		26mm	70mm	230mm	
6-613-850100040	IVECO, MAN 	90mm		26mm	85mm	230mm	

www.hardyspicer.com.au

Document No:	HSDSCAT
Issue:	15
Issue Date:	03/11/14

This catalogue is the copyright of Hardy Spicer

Hardy Spicer "D" shape						
Hardy Spicer Part No.	Description	Centre Height	Bearing & retainer	Bearing Width	Bearing ID	Bolt Hole Centres
211590-1X	 FORD RANGER 300C LIMO	49mm		16mm	30mm	149mm
210088-1X	 1310 1350 1410	57.1mm	210086X	27mm	35mm	168mm
211187X	 Suits Ford F100, F150 etc.	57.1mm		27mm	35mm	168mm
210433-1X	 1350 1410 1480 1550 Suits slip yokes	62mm	210085-1X	27mm	40mm	168mm
210866X	 1350 1410 1480 1550 Suits slip yokes	57.1mm		27mm	40mm	168mm
210391-1X	 1350 1410 1480 1550 Suits end yokes	62mm	210085-1X	27mm	40mm	168mm
210084-2X	 1480 1550 1610	68.3mm	210092-1X	27mm	45mm	194mm
211604-1X	 1480 1550 1610 Solid Rubber 70 Shore	68.3mm	210092-1X	27mm	45mm	194mm

www.hardyspicer.com.au

Document No:	HSDSCAT
Issue:	15
Issue Date:	03/11/14

This catalogue is the copyright
of Hardy Spicer

Hardy Spicer "D" shape cont.

Hardy Spicer Part No.	Description	Centre Height	Bearing & retainer	Bearing Width	Bearing ID	Bolt Hole Centres
210121-1X	 1710	70.6mm	210120-1X	30mm	50mm	194mm
210881-1X	 1710 Solid rubber	70.6mm	210120-1X	30mm	50mm	194mm
211440X	 18mm wide bearing	70.6mm		18mm	55mm	194mm
210661-1X	 1710 1760 1800 1810	85.7mm	210660-1X	36mm	60mm	219mm
210875-1X	 1710 1760 1800 1810 Solid rubber	85.7mm	210660-1X	36mm	60mm	219mm
5003323XB	 Self Aligning Bearing Fluted rubber	84.6mm		36mm	60mm	219mm
5003326XB	 Self Aligning Bearing Solid rubber	84.6mm		36mm	60mm	219mm

www.hardyspicer.com.au

Document No:	HSDSCAT
Issue:	15
Issue Date:	03/11/14

This catalogue is the copyright of Hardy Spicer

Hino

Vehicle	Model	Hardy Spicer Part No.	O.E.Part No.	Year	Bearing ID	Bolt Hole Centres
FD2H		HI-30-6060	37230-1200		45mm	
KR		HI-30-6050	37230-1171		45mm	
FL3H / FM3H		HI-30-6350	37404-1080		50mm	

Holden

Vehicle	Model	Hardy Spicer Part No.	O.E.Part No.	Year	Bearing ID	Bolt Hole Centres
Captiva		HO-30-7060	96624771		30mm	190.5mm
Commodore VB - VT	 VB-VT	CB-952 (60 Duro)	M40306	All	30mm	
Commodore VX - VZ	 V6 Sedan V6 Wagon/Ute V8 Sedan V8 Wagon/Ute	UD-30-5640 UD-30-5650 UD-30-5660 UD-30-5670			30mm 30mm 30mm 30mm	195mm 195mm 195mm 195mm
Commodore VE	 V6, V8 Ute Sedan & Wagon	HO-30-6177	10086177	ALL	30mm	187.6mm
Crewman	 Including Brackets	HO-30-9157			30mm	
Sunbird	 Bearing & Rubber	17R-30-1110			30mm	
Statesman VQ, VR, VS WH Series I		CB-952 (60 Duro)		90-8/01	30mm	

www.hardyspicer.com.au

Document No:	HSDSCAT
Issue:	15
Issue Date:	03/11/14

Holden cont.

Vehicle	Model	Hardy Spicer Part No.	O.E.Part No.	Year	Bearing ID	Bolt Hole Centres
Statesman WH Series II WK, WM	 V6 All	UD-30-5650		8/01-	30mm	195mm
Statesman WH Series II WK, WM	 V8	UD-30-5670			30mm	195mm
Jackaroo 4WD & Rodeo 4WD	 UBS Long wheel base KB	IS-30-3910		8/85-	25mm	50mm
Rodeo 2WD	 TF (Centre to Mounting flange 100mm)	IS-30-4010	8-94328-800	89-	30mm	94mm
Rodeo 4WD	 TF (Centre to Mounting flange 85mm)	IS-30-4110	8-94482-472 8-94386-854 8-94328-799-0	87-	30mm	94mm
COLORADO 4X4	 Double Sided Rubber Insert	IS-30-7160		7/08-6/12	30mm	94mm

Honda

Vehicle	Model	Hardy Spicer Part No.	O.E.Part No.	Year	Bearing ID	Bolt Hole Centres
CRV	 HO-30-6010	HO-30-6010	405210-S10-003	97-01	25mm	174mm
CRV	 HO-30-6020	HO-30-6020		03-05	25mm	174mm
CRV	 HO-30-6030	HO-30-6030		07-11	25mm	174mm

www.hardyspicer.com.au

Document No:	HSDSCAT
Issue:	15
Issue Date:	03/11/14

This catalogue is the copyright of Hardy Spicer

Hyundai

Vehicle	Model	Hardy Spicer Part No.	O.E.Part No.	Year	Bearing ID	Bolt Hole Centres
SANTA FE		MI-30-4510A			30mm	160mm (25mm Holes)

Isuzu

Vehicle	Model	Hardy Spicer Part No.	O.E.Part No.	Year	Bearing ID	Bolt Hole Centres
D MAX 4X4		IS-30-7160	8-97942877-0		30mm	94mm
Forward	4-5 tonne 7 tonne 	IS-30-5110	1-37510-035-0 1-37510-105-0	1982- 1984-	45mm 45mm	155mm 155mm
F SERIES	Hex Solid Rubber 	IS-30-7150	9-37516045-1	1988-	50mm No Seals	
N SERIES	4 Hole bracket 	IS-30-5620 IS-30-5610	5-37510-008-0 5-37510-007-0	1985-	32mm 40mm	
N SERIES		IS-30-7050	8-971311143-1		45mm	
687-50 SERIES	Suits shafts with Hi-Torque flanges 	6-613-550100690			55mm	200mm
		IS-30-7170	1-37510093-0		55mm	295mm
		IS-30-7180	1-37510094-0		60mm	295mm

www.hardyspicer.com.au

Document No:	HSDSCAT
Issue:	15
Issue Date:	03/11/14

This catalogue is the copyright of Hardy Spicer

Iveco						
Vehicle	Model	Hardy Spicer Part No.	O.E.Part No.	Year	Bearing ID	Bolt Hole Centres
IVECO DAILY	 22mm Wide Bearing	IV-30-9056	42535254		40mm	168mm
IVECO TRUCK 687-30 687-35	 19mm Wide Bearing 68.3mm centre height	211447X			45mm	194mm
IVECO TRUCK 587-20 587-30	 36.6mm Wide Bearing	6-387-300127080			55mm	200mm
IVECO TRUCK 687-40 687-45	 Sealed Bearing 22mm Wide	IV-30-9194			55mm	220mm
IVECO TRUCK 587-35 587-36	 36.6mm Wide Bearing 80mm centre height	6-187-400100010			60mm	200mm
IVECO TRUCK Klein 590 Shaft	 19mm Wide Bearing	IV-30-9041	93194978		65mm	200mm
IVECO TRUCK	 20mm Wide Bearing 85.8mm centre height Soft Solid Rubber	6-113-700127190			70mm	220mm
IVECO TRUCK 687-55 687-60 687-65	 20mm Wide Bearing 85.8mm centre height Solid Rubber	6-113-700184060			70mm	220mm
	 43mm Wide Bearing 88mm centre height	126-700-10202			70mm	220mm Ø15mm
IVECO TRUCK 687-40 687-45 Klein 490	 26mm Wide Bearing 90mm centre height	6-613-750100090			75mm	230mm

www.hardyspicer.com.au

Document No:	HSDSCAT
Issue:	15
Issue Date:	03/11/14

This catalogue is the copyright of Hardy Spicer

Iveco cont.

Vehicle	Model	Hardy Spicer Part No.	O.E.Part No.	Year	Bearing ID	Bolt Hole Centres
IVECO TRUCK 687-55	 <p>26mm Wide Bearing 90mm centre height Suit reverse slip style</p>	6-613-850100040			85mm	220mm

Jaguar

Vehicle	Model	Hardy Spicer Part No.	O.E.Part No.	Year	Bearing ID	Bolt Hole Centres
Jaguar	 <p>XJ Models 1979-1997</p>	VOL-30-6240	3180-3002	79-97	30mm	76mm Threaded
Jaguar	 <p>X Type AWD</p>	JAG-30-7280			65mm 18mm Wide	170mm

Land Rover

Vehicle	Model	Hardy Spicer Part No.	O.E.Part No.	Year	Bearing ID	Bolt Hole Centres
Freelander	 <p>2 Required per vehicle</p>	LR-30-6260	T0Q000040		30mm	138mm
Range Rover Sport	 <p>Centre Height 65mm</p>	LR-30-0390	TVB500390 LR037028	05-09	30mm 13mm Wide	130mm
Range Rover Mark 3	 <p>Centre Height 47mm</p>	LR-30-0400	TVB500400 LR030049	02-09	30mm 13mm Wide	160mm
Land Rover Discovery Mark 3	 <p>Centre Height 58mm</p>	LR-30-0360	TVB500360	04-09	30mm 13mm Wide	130mm

www.hardyspicer.com.au

Document No:	HSDSCAT
Issue:	15
Issue Date:	03/11/14

Mack

Vehicle	Model	Hardy Spicer Part No.	O.E.Part No.	Year	Bearing ID	Bolt Hole Centres
	Suits Mack trucks 	A34MU336	A34MU336		60mm	

Man

Vehicle	Model	Hardy Spicer Part No.	O.E.Part No.	Year	Bearing ID	Bolt Hole Centres
MAN 587-20 587-30	36.6mm wide bearing 	6-387-300127080			55mm	200mm
MAN 587-35 587-36	36.6mm wide bearing 80mm centre height 	6-187-400100010			60mm	200mm
MAN 587-35 587-42 687-40 687-45	23mm wide bearing 85.8mm centre height Solid Rubber 	6-613-6501AU650			65mm	225mm
MAN 687-40 687-45	26mm wide bearing 85mm centre height Suit reverse slip style 	6-613-750100090			75mm	230mm
MAN 687-55	26mm wide bearing 90mm centre height Solid Rubber Suit reverse slip style 	6-613-850100040			85mm	220mm

Maserati

Vehicle	Model	Hardy Spicer Part No.	O.E.Part No.	Year	Bearing ID	Bolt Hole Centres
BITURBO	52mm Centre Height 	MA-30-6990			30mm	84mm (8mm)

www.hardyspicer.com.au

Document No:	HSDSCAT
Issue:	15
Issue Date:	03/11/14

This catalogue is the copyright of Hardy Spicer

Mazda

Vehicle	Model	Hardy Spicer Part No.	O.E.Part No.	Year	Bearing ID	Bolt Hole Centres
B1600 B1800 Some early B2000 / B2200 Up to 1985	 B1600 B1800	MZ-30-4210	0755-25-300	77-	25mm	150mm
B2000/B2200 B2600/Courier early with 25mm bearing	 Suits Petrol & Diesel	MZ-30-4310	P027-25-310A P030-25-310A	85-	25mm	165mm
B2600	 Carby Models	MZ-30-4910	P045-25-310	85-89	28mm	170mm
B2600	 2WD EFI Models	MZ-30-5780	P047-25-310A	-1/99	28mm	164mm
B2600	 4WD Models	MZ-30-5680	P065-25-310A	-1/99	28mm	180mm
B2600 2WD	 2WD Models EFI & Diesel	MZ-30-6900	SA02-25-100	2/99-06	28mm	161mm
B2600 4WD	 4WD Models	MZ-30-6910	SA54-25-100	2/99-06	28mm	180mm

www.hardyspicer.com.au

Document No:	HSDSCAT
Issue:	15
Issue Date:	03/11/14

Mazda cont.

Vehicle	Model	Hardy Spicer Part No.	O.E.Part No.	Year	Bearing ID	Bolt Hole Centres
BT-50 2WD BT-50 4WD	3.0DT MAN 3.0DT AUTO 3.0DT 	FD-30-7040	SA68-25-300A	11/06-10/11 11/06-10/11 11/06-8/08	35mm	180mm
BT-50 2WD	2.5 DT 	FD-30-7030		06-10/11	35mm	164mm
929		MZ-30-5740	8593-25-300A	80-82	25mm	150mm
929		MZ-30-5560	M011-22-560	82-83	25mm	162mm
929		MZ-30-5570	M025-22-560	84-87	25mm	152mm
929		MZ-30-5580	M046-22-560	88-91	25mm	153mm
929	Automatic 	MZ-30-5520	M053-25-310	88-91	25mm	160mm
929		MZ-30-5810	P036-25-310A	88-91	28mm	

www.hardyspicer.com.au

Document No:	HSDSCAT
Issue:	15
Issue Date:	03/11/14

This catalogue is the copyright of Hardy Spicer

Mazda cont.

Vehicle	Model	Hardy Spicer Part No.	O.E.Part No.	Year	Bearing ID	Bolt Hole Centres
CX9		FD-30-5840 Bearing & Rubber only			mm	mm
Tribute	V6 Auto 	FD-30-6970			30mm	175mm
T Series Trader		MZ-30-5590	W001-25-310 W001-25-321		35mm	180mm
T Series Trader (without bracket)		MZ-30-5590BR			35mm	

www.hardyspicer.com.au

Document No:	HSDSCAT
Issue:	15
Issue Date:	03/11/14

This catalogue is the copyright
of Hardy Spicer

Mercedes

Vehicle	Model	Hardy Spicer Part No.	O.E.Part No.	Year	Bearing ID	Bolt Hole Centres
W201 Series 190E 190D		MER-30-6200	2014100581	82-93 85-93 86-89	25mm	110.5mm
W124, C124, S124, 260E		MER-30-6950	1244100181	84-93 88-90	25mm	118mm
W124, W126 350E, D		MER-30-6180	1244100281	71-93 86-	30mm	116mm
W126, C126 380SEL		MER-30-6190	1264100181	79-91 82-83	30mm	120mm
W123 230 280 300D 300TD 380SL		MER-30-6940	1234101081	77-78 77-81 76-82 82-85 82-85	30mm	131mm
Vito Front "O" Shape		MB-30-0081	6394100081		30mm	148mm
Vito Rear "D" Shape		MB-30-0281	6394100281		30mm	148mm
Sprinter		MB-30-9025	901-410-0312		45mm	194mm
Sprinter (New)	 73mm Centre Height	MB-30-9223			47mm	194mm

www.hardyspicer.com.au

Document No:	HSDSCAT
Issue:	15
Issue Date:	03/11/14

This catalogue is the copyright
of Hardy Spicer

Mercedes cont.

Vehicle	Model	Hardy Spicer Part No.	O.E.Part No.	Year	Bearing ID	Bolt Hole Centres
Truck	Suits 385 Series (Octagonal Style) 	MB-30-9009			45mm	27mm
Truck 190mm Wide Housing	Suits 385 Series (New Shape) 25mm Wide Bearing Replaces Octagonal shape 	MB-15855	385-410-0922		55mm	27mm
Atego	"D" Shape Bearing 	MB-30-9023			45mm	35mm M12.5x1.5
Atego	"D" Shape Bearing 	MB-30-9141			55mm	35mm M12.5x1.5
Atego	"D" Shape Bearing 	MB-30-9143	654-411-0012		60mm	35mm M12.5x1.5
389 Series 247mm Wide Housing		MB-11760	389-410 0222		60mm	50mm
Actros		MB-30-9096	656-411-0112		70mm	35mm M12.5x1.5
395 Series 242mm Wide Housing	25mm Wide Bearing 	MB-30-9015	395-410-0622		70mm	
	22mm Wide Bearing 	MB-30-9139			70mm	

www.hardyspicer.com.au

Document No:	HSDSCAT
Issue:	15
Issue Date:	03/11/14

Mitsubishi						
Vehicle	Model	Hardy Spicer Part No.	O.E.Part No.	Year	Bearing ID	Bolt Hole Centres
Canter		MI-30-5630	MB000076 MB000083 MB563228	80-89	35mm	170mm
				85-89	35mm	170mm
L200 Scorpion		MI-30-5730	MB154080	79-	30mm	165mm
GALANT HH VR TURBO LANCER EVO (Some) 3000GT, GTO	2 per Vehicle 	MI-30-6930	MB505495		30mm	190mm Diagonal 178mm Parallel
Lancer EVO Bearing and Rubber Only		MI-30-7010		97-	30mm	N/A
Triton 2WD	Without seals 	MI-30-4510	MB154199 MR357998	86-	30mm	160mm
Triton 2WD KA4T, KB4T 4WD ML, MN		MI-30-7020	MR580647	05-	30mm	160mm
L300 4WD Star Wagon		MI-30-4510A	MR165252	98-	30mm	160mm (25mm Holes)
Triton 4WD	With seals 	MI-30-4610	MB154706	86-	30mm	160mm
FE439, FE444 FE449		MI-30-6020	MB563234A		40mm	170mm

www.hardyspicer.com.au

Document No:	HSDSCAT
Issue:	15
Issue Date:	03/11/14

This catalogue is the copyright of Hardy Spicer

Mitsubishi cont.

Vehicle	Model	Hardy Spicer Part No.	O.E.Part No.	Year	Bearing ID	Bolt Hole Centres
FK415, 515		MI-30-6040	MC824410A		45mm	
FUSO		MI-30-6030	MC881040A		55mm	

Nissan

Vehicle	Model	Hardy Spicer Part No.	O.E.Part No.	Year	Bearing ID	Bolt Hole Centres
620		NP-30-5720				
720 E20	 720G. 720S.720 (2WD & 4WD)	NP-30-A3710	37521-01W25	79-85	30mm	
300ZX	 300ZX	NP-30-5010 NP-30-5820	37521-33P27 Aus Production 37521-33P25 Jap Import	89- 89-	30mm 30mm	144mm 144mm
Skyline / Laurel R32-R33		NP-30-6250			30mm	155mm
300ZX Skyline / Laurel R32-R33	 BEARING AND RUBBER	NP-30-6260		89-	30mm	
Caball H40, H41 Civilian W40, W41		NP-30-7300	37521-J2100		30mm	

www.hardyspicer.com.au

Document No:	HSDSCAT
Issue:	15
Issue Date:	03/11/14

This catalogue is the copyright of Hardy Spicer

Nissan cont.

Vehicle	Model	Hardy Spicer Part No.	O.E.Part No.	Year	Bearing ID	Bolt Hole Centres
Bluebird Navara Skyline Stanza Pintara 300ZX	4 spd manual 2WD Japanese Production 280C RD28. CA180D. 180DT  110mm OD, 39mm width over rings	NP-30-A3410	37521-W1025 37521-W1025 37521-Q0125 37521-41L25	-6/83 9/85- 81-86 87- 86-90 84-89	30mm 30mm 30mm 30mm	
Bluebird Stanza 200B	5 spd manual  110mm OD, 43mm width over rings	17R-30-2610	37521-V9625	-6/82 78-83 79-81	30mm 30mm 30mm	
Navara D40 2WD	Centre height 57mm 	NP-30-7040	37522-JR60A	05-	45mm 19mm wide	168mm
Navara	4WD 	NP-30-A3510	37521-32G25 37521-33G25 37521-56G25	8/87-	30mm	
Skyline R31	Australian Production 	CB-952	37521-J7085	7/86-	30mm	
UD	Diesel truck 50mm 	UD-30-5530	37510-Z5002		50mm	
UD	Diesel truck 55mm 	UD-30-5540	37510-Z2002		55mm	
UD	Diesel truck 60mm 	UD-30-5550	37510-90017		60mm	

www.hardyspicer.com.au

Document No:	HSDSCAT
Issue:	15
Issue Date:	03/11/14

This catalogue is the copyright
of Hardy Spicer

Porsche

Vehicle	Model	Hardy Spicer Part No.	O.E.Part No.	Year	Bearing ID	Bolt Hole Centres
Cayenne Cayenne Turbo		VW-30-9168			30mm (20mm Wide)	68mm (Offset)

Renault

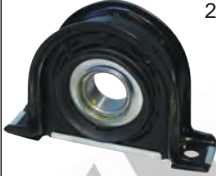
Vehicle	Model	Hardy Spicer Part No.	O.E.Part No.	Year	Bearing ID	Bolt Hole Centres
	 22mm wide bearing	H81-000-2			60mm	200mm

Scania

Vehicle	Model	Hardy Spicer Part No.	O.E.Part No.	Year	Bearing ID	Bolt Hole Centres
	 Suits Scania truck	SC-47-959-1X			55mm	
	 Suits Scania truck 85mm Seal 22mm wide bearing Relube	SC-47-985-1X	1113031		60mm	
P300, P400 P500 & P600	 Suits Scania truck 26mm wide bearing Service Free	SC-30-9108	1387764	2006 -	60mm	

Subaru

Vehicle	Model	Hardy Spicer Part No.	O.E.Part No.	Year	Bearing ID	Bolt Hole Centres
Impreza Liberty	Some 	SUB-30-6160	27037AA010	1997-	25mm	172mm
Impreza / WRX	Some 	SUB-30-6170	27037AK010	1997-	30mm	169mm

www.hardyspicer.com.au

Document No:	HSDSCAT
Issue:	15
Issue Date:	03/11/14

SSANGYONG

Vehicle	Model	Hardy Spicer Part No.	O.E.Part No.	Year	Bearing ID	Bolt Hole Centres
ACTYON SPORTS REXTON Early models	Centre Height 73mm	SS-30-0240			30mm 16mm	45mm M12x1.25
MUSSO SPORTS	Centre Height 98mm	SS-30-0243			30mm 16mm	45mm M12x1.25
REXTON Late models	Centre Height 80mm	SS-30-2420			30mm 16mm	47mm M12x1.25

TORO

Vehicle	Model	Hardy Spicer Part No.	O.E.Part No.	Year	Bearing ID	Bolt Hole Centres
TORO VARIOUS	Width across seals 48mm Bearing width 31mm Centre Height 78mm 	TORO-30-9292	29605746		70mm	210mm

www.hardyspicer.com.au

Document No:	HSDSCAT
Issue:	15
Issue Date:	03/11/14

This catalogue is the copyright of Hardy Spicer

Toyota

Vehicle	Model	Hardy Spicer Part No.	O.E.Part No.	Year	Bearing ID	Bolt Hole Centres
Celica Corona	 RA40 XT130 Sedan & Wagon	17R-30-2110	37230-14031 37230-14031	11/77-10/81 10/79-7/83	30mm 30mm	151mm
Celica Corona Cressida Supra 2WD Tercel	 RA60 ST141 Sedan & Wagon MX73. GX71 MA61 2 door liftback AL25 4WD	17R-30-2710	37230-24010 37230-24010 37230-24020 37230-24010 37230-24020	11/81-9/83 8/83-11/84 84-88 10/83-85 82-88	30mm 30mm 30mm 30mm 30mm	150mm
Corolla Sprinter 2WD	 TE 70E. 71E. CE 70E. KE70 TE70. CE70F	17R-30-2310	37230-12040 37230-12040	79-87 79-83		163mm
Corolla	 AE95 FR 3PC	17R-30-6130	37230-12081 37230-12140 27230-12141	84-87	30mm	151mm
Corolla	 AE95 (REAR) 3PC	17R-30-6140	37230-12091 37230-12150 27230-12151	84-87	30mm	148mm
Corona	 RT132 133 Lift backs	17R-30-2410	37230-20090	10/79-82		
Cressida	 GX60	17R-30-6110	37230-22042	76-85	30mm	165mm
Cressida	 MX83	17R-30-6120	37230-22110	89-93	30mm	150mm
Crown	 MS80, 90,100	17R-30-6080	37230-30022	74-79	30mm	112mm

www.hardyspicer.com.au

Document No:	HSDSCAT
Issue:	15
Issue Date:	03/11/14

This catalogue is the copyright
of Hardy Spicer

Toyota cont.

Vehicle	Model	Hardy Spicer Part No.	O.E.Part No.	Year	Bearing ID	Bolt Hole Centres
Crown	MS112	17R-30-6090	37230-30030	79-83	30mm	120mm
						
Crown	MS122, 3, 5	17R-30-6100	37230-30050	-91	30mm	140mm
						
Dyna Coaster	RU30, BU30, BU45 RU20, BB20, HB30, BU80, BU90, YU80, WU90	TD-30-A3010	37230-36060	81-88	30mm	125mm
						
Coaster 93-	80mm Centre Height HZB50L	TD-30-6270	37230-36140	93-	30mm	125mm
						
Sprinter 2WD	AE86	17R-30-5310	37230-12050	83-87	30mm	155mm
						
Supra Soarer	GZ20 MA70	17R-30-6160	37230-14070	88-93 88-93 8/87-8/88	30mm	142mm
						
Hiace Commuter	RZH125, RZH135, LH184 LH125	TH-30-5800	37230-26010	89-1/05 89-8/00	30mm	150mm
						
Hiace Commuter	KDH223, TRH223 2.5mm offset on centre height	TH-30-9055	37230-29055	1/05-6/10	30mm	148.4mm
						
Hiace / SBV Spacia Town-Ace Lite-Ace	LXH, KLH, RCH12, 22 SR40 CR4# KR4#	TH-30-7000	37230-26020	95-06 11/96-04 11/96-04 11/96-04	30mm	148mm
						

www.hardyspicer.com.au

Document No:	HSDSCAT
Issue:	15
Issue Date:	03/11/14

This catalogue is the copyright of Hardy Spicer

Toyota Cont.

Vehicle	Model	Hardy Spicer Part No.	O.E.Part No.	Year	Bearing ID	Bolt Hole Centres
Hilux	 RN15 Stout	TH-30-5760	37230-35013	69-75	30mm	80mm
Hilux 2WD	 RN25, LN25	TH-30-5410	37230-40031	75-78	30mm	109mm
Hilux 2WD	 LN40, 41, RN40 (uses 8mm bolts)	TH-30-5510	37230-35030	79-82	30mm	150mm
Hilux 2WD	 YN55, 56, 57, 58, LN55, 56 (uses 10mm bolts) YN85, LN85	TH-30-A3210	37230-35050	8/83-7/88	30mm	150mm
Hilux 2WD			37230-35070	8/88	30mm	150mm
Hilux 2WD	 YN85 LN85	TH-30-4710	37230-35090	90-	30mm	155mm
Hilux 2WD	 RZN147, 149, 154 LN147R	TH-30-5750	37230-35120	97-2/05	30mm	148mm
Hilux 2WD	 GGN15R TGN16R KUN16R	TH-30-6800	37230-0K020 37230-0K021	3/05-	30mm	152mm
Hilux 4WD	 YN65, 67 LN65 YN106 LN106	TH-30-4810	37230-35060 37230-35061 37230-35080	8/83-97	30mm	240mm
Hilux 4WD	 LN167, LN172 VZN167R RZN169R	TH-30-5770	37230-35130	97-2/05	30mm	148mm

www.hardyspicer.com.au

Document No:	HSDSCAT
Issue:	15
Issue Date:	03/11/14

Toyota cont.

Vehicle	Model	Hardy Spicer Part No.	O.E.Part No.	Year	Bearing ID	Bolt Hole Centres
Hilux 4WD	KUN26R GGN25R 	TH-30-6810	37230-0K010 37230-0K011	3/05-	30mm	152mm
Kluger & Lexus RX300	Front Bearing 	17R-30-6280	37230-48010 37230-49015	99-	30mm	177.5mm
Kluger & Lexus RX300	Rear Bearing 	17R-30-6290	37230-21020 37230-29015	99-	30mm	177.5mm
Rav4		17R-30-6150	37230-42010	94-00	30mm	198mm
Rav4		17R-30-6240	37230-20130	7/00- 11/05	30mm	176mm
Rav4 AWD ACA33		17R-30-2090		11/05- 11/12	25mm	168mm
Tarago 4WD		17R-30-6070	37230-28010		30mm	151mm

www.hardyspicer.com.au

Document No:	HSDSCAT
Issue:	15
Issue Date:	03/11/14

This catalogue is the copyright of Hardy Spicer

Toyota Cont.

Vehicle	Model	Hardy Spicer Part No.	O.E.Part No.	Year	Bearing ID	Bolt Hole Centres
	 Bearing & Rubber insert	17R-30-5790			30mm	
	 Passenger vehicle bearing & rubber	17R-30-1110		77-94	30mm	
Celica ST184/185 AWD Corolla AE95,AWD RAV4 Kluger Lexus RX300	 Bearing & Rubber insert 35mm Seals each side	17R-30-6170	37230-20020A	94-00	30mm	

Volvo

Vehicle	Model	Hardy Spicer Part No.	O.E.Part No.	Year	Bearing ID	Bolt Hole Centres
850	 Volvo shaft with CV each end	VOL-30-6240			30mm	76mm Threaded
740, 760		VOL-30-6220	1209820	88-91	35mm	80mm
740, 760		VOL-30-6210	1340501	88-91	45mm	80mm
940, 960		VOL-30-6230	1209821		40mm	80mm

www.hardyspicer.com.au

Document No:	HSDSCAT
Issue:	15
Issue Date:	03/11/14

Volvo cont.						
Vehicle	Model	Hardy Spicer Part No.	O.E.Part No.	Year	Bearing ID	Bolt Hole Centres
Truck	69.1mm centre height 18mm wide bearing Solid Rubber Relube 	6-613-550100560			55mm	200mm
Truck 687-35 687-40 687-45	71.5mm centre height 18mm wide bearing 	6-613-550100690			55mm	200mm
Truck	Suits Volvo 300 & 400 series 	VOL-23220	621235		60mm	198mm
Wheel Loader	Relube Bearing Solid Rubber 80 Shore 	VOL-30-9119	6212888		60mm	198mm
Truck	Suits Volvo 500 & 600 series 	VOL-24552	263567		70mm	198mm
Truck	85.8mm centre height 20mm wide bearing Solid Rubber 687-60/65 	6-113-700184060	1068222		70mm	220mm
Truck	85mm centre height 26mm wide bearing 687-55/60/65 Genuine Part 	VOL-21082632	21082632 (Inc. slingers) 21081171 (No slingers)		70mm	220/230 mm

www.hardyspicer.com.au

Document No:	HSDSCAT
Issue:	15
Issue Date:	03/11/14

This catalogue is the copyright of Hardy Spicer

VW

Vehicle	Model	Hardy Spicer Part No.	O.E.Part No.	Year	Bearing ID	Bolt Hole Centres
Crafter		MB-30-9223			47mm	194mm
Touareg		VW-30-9168			30mm (20mm Wide)	68mm (Offset)

www.hardyspicer.com.au

Document No:	HSDSCAT
Issue:	15
Issue Date:	03/11/14

This catalogue is the copyright of Hardy Spicer

RUBBER DRIVE COUPLINGS



AUDI

Application	Image	Part No.	PCD	Bolt Dia	OD	Bore	Width
AUDI AWD	 <p>Steel Shroud</p>	GAV-01-003	105mm	10mm 6 Holes			26mm C/Sunk

BMW

Application	Image	Part No.	PCD	Bolt Dia	OD	Bore	Width
		100-R249	78mm	10mm	103mm	40mm	28mm
3 Series 318i, 320i, 323i, 325i, 328i Z Series 95-06 With OEM# 26111227410		GAH04-001-0 GAB-74-0	78mm	12mm	111mm	38mm	32mm
3 Series / 5 Series 325xi, 330xi, 528xi X3, X5 & X6 Series With OEM# 26111229360		GAB01-017-0 GAB-87-0	96mm	12mm	132mm	50mm	30mm Inc. 18mm Spigot
BMW		GAB01-026-0	110mm	12mm			38.5mm

CHRYSLER

Application	Image	Part No.	PCD	Bolt Dia	OD	Bore	Width
Chrysler 300C 6cyl Petrol & Diesel		GAC02-001-0	100mm	12mm	137mm	50mm	28.5/32mm Inc. 18mm Spigot
Chrysler 300C V8		GAC02-002-0	110mm	12mm	148mm	58mm	31/35mm Inc. 18mm Spigot

www.hardyspicer.com.au

Document No:	HSDSCAT
Issue:	15
Issue Date:	03/11/14

This catalogue is the copyright
of Hardy Spicer

FORD

Application	Image	Part No.	PCD	Bolt Dia	OD	Bore	Width
BA FALCON 6 cyl (EXCEPT TURBO) 5 Speed MAN/4 Speed AUTO BF FALCON 6 cyl 5 Speed MAN/4 Speed AUTO		GAJ-1-0	96mm	12mm	134mm	50mm	35mm
BA/BF SERIES I FALCON V8 & TURBO 6 cyl BA MKII 6 cyl 6 Speed AUTO BF 6 cyl SERIES I 6 Speed AUTO		GAG03-001-0	105mm	12mm	142mm	56mm	32/35mm Inc. 18mm Spigot
BF FALCON SERIES II on FG FALCON		GAD03-001-0	110mm	12mm	148mm	56mm	32/35mm Inc. 18mm Spigot
TRANSIT		GAF01-003-0	105mm	12mm	142mm	56mm	32/35mm Inc. 18mm Spigot
TRANSIT		GAF01-002-0	120mm	14mm	160mm	64mm	40.5 / 43.5mm Inc. 20mm Spigot

www.hardyspicer.com.au

Document No:	HSDSCAT
Issue:	15
Issue Date:	03/11/14

HOLDEN

Application	Image	Part No.	PCD	Bolt Dia	OD	Bore	Width
COMMODORE VS / VT V6 MANUAL (Front only) (comes complete with 96RC-100-344 coupling, 6 bolts, 6 lock nuts & centre bush)		RCA-1059	96mm	12mm	133mm	49mm	30mm
COMMODORE VT SERIES 1 UP TO 6/99 V8 MANUAL (Front only) (includes 100-R337 coupling)		RCA-1058	100mm	12mm	149mm	41mm	36/40mm Inc. 18mm Spigot
COMMODORE VT SERIES 2 6/99 ON 5.7L V8 GEN 3 MANUAL ONLY (Front only)		10005422 ¥	96mm	12mm	133mm	49mm	35/38mm Inc. 18mm Spigot
COMMODORE VX-VZ VE UP TO 03/2008 V6 AUTO FRONT & REAR V6 MANUAL FRONT ONLY (comes complete with 96RC-100-344 coupling, 6 bolts, 6 lock nuts)		RCA-1060	96mm	12mm	132mm	50mm	30mm
COMMODORE VX-VZ V8 MANUAL & AUTO F&R ALL VX-VE TO 03/08 REAR (EXCEPT V6 AUTO) (comes complete with 100-R324 coupling, 3 bolts, 3 lock nuts)		RCA-1061	96mm	12mm	133mm	49mm	35mm
COMMODORE VE V8 FRONT & REAR CREWMAN 2004 on V8 AUTO VZ CAB CHASSIS (SOME VZ HSV APPLICATIONS) (comes complete with coupling, 6 bolts, 6 lock nuts & centre bush)		RCA-1062	110mm	12mm	152mm	58mm	35/38.5mm Inc. 18mm Spigot
COMMODORE VE V6 FRONT & REAR 3/2008 on		10175274	105mm	12mm	141mm	56mm	32/35mm Inc. 18mm Spigot

¥ Available while stock lasts, replacement part is 3mm thinner (32/35) with same rating.

CENTERING BUSH

Application	Image	Part No.	Length	OD	Bore
SUITS MOST COMMODORE & MOST FORD SHAFTS		UD-32-140	48.5mm	32mm	16mm
SUITS COMMODORE 14mm MAINLY FIXED G/BOX FLANGE TYPE		UD-32-138	48.5mm	32mm	14mm

www.hardyspicer.com.au

Document No:	HSDSCAT
Issue:	15
Issue Date:	03/11/14

This catalogue is the copyright of Hardy Spicer

HYUNDAI

Application	Image	Part No.	PCD	Bolt Dia	OD	Bore	Width
SANTA FE V6 TUCSON		GAH04-001-0	78mm	12mm	111mm	38mm	32mm
SANTA FE (LATER MODELS)		GAH04-003-0	90mm	10mm	128mm	42mm	32mm

KIA

Application	Image	Part No.	PCD	Bolt Dia	OD	Bore	Width
SPORTAGE V6 2.7L		GAH04-001-0	78mm	12mm	111mm	38mm	32mm

LAND ROVER

Application	Image	Part No.	PCD	Bolt Dia	OD	Bore	Width
DISCOVERY (REAR)		GAG1-0	96mm	12mm	131mm	50mm	30mm

www.hardyspicer.com.au

Document No:	HSDSCAT
Issue:	15
Issue Date:	03/11/14

MERCEDES							
Application	Image	Part No.	PCD	Bolt Dia	OD	Bore	Width
MERCEDES C240, C320		GAD01-003-0 # (126 410 0115) (126 586 0141)	90mm	10mm (6 Holes)			32mm Inc. Spigot
MERCEDES 250, 280		GN-140-0 # (126 410 0115) (126 586 0141)	90mm	10mm (6 Holes)			29mm Inc. Spigot
W140		GAD-138-0	110mm	12mm (8 Holes)	149mm	60mm	27/30mm Inc. 18mm Spigot
W123 UP TO 1987 200, 380, 420, 500 SE, SL & SEL		GN-132-0 (126 410 0415) (126 411 0215)	110mm	12mm (6 Holes)	150mm	53mm	22/26mm Inc. 18mm Spigot

NISSAN							
Application	Image	Part No.	PCD	Bolt Dia	OD	Bore	Width
PINTARA MANUAL FRONT		100-R231	96mm	10mm	133mm	45mm	30mm
PINTARA AUTO FRONT		100-R249	78mm	10mm	103mm	40mm	28mm

www.hardyspicer.com.au

Document No:	HSDSCAT
Issue:	15
Issue Date:	03/11/14

This catalogue is the copyright
of Hardy Spicer

Indent item only

RENAULT

Application	Image	Part No.	PCD	Bolt Dia	OD	Bore	Width
SCENIC		GAR03-003-0	80mm	10mm	125mm	33mm	33/36.5mm Inc. 16mm Spigot
SCENIC With Dampner Ring (not shown)		TTR03-003-0	80mm	10mm	125mm	33mm	33/36.5mm Inc. 16mm Spigot

SKODA

Application	Image	Part No.	PCD	Bolt Dia	OD	Bore	Width
SKODA AWD	Steel Shroud 	GAV-01-003	105mm	10mm 6 Holes			26mm C/Sunk

TOYOTA

Application	Image	Part No.	PCD	Bolt Dia	OD	Bore	Width
TARAGO AUXILLARY SHAFT (12mm Locating bush) Petrol 5/90 - 1/94 ^		TO-PC-305P-12 ^	80mm	8mm	125mm	40mm	20mm
TARAGO AUXILLARY SHAFT (14mm Locating bush) Petrol 1/94-12/99 OEM # 04374-28010		TO-PC-305P-14	80mm	8mm	125mm	40mm	20mm
TARAGO AUXILLARY SHAFT (14mm Locating bush) Diesel		TO-PC-306D-14	85mm	8mm	129mm	42mm	20mm
SOARER		GAF01-003-0*	105mm	12mm	142mm	56mm	32/35mm Inc. 18mm Spigot

^ Some models may have 14mm locating bushes as Toyota superseded complete shaft assembly to the 94 on as a complete assembly for replacement.

* Some models may require modifications to spigot bushes as some have 21mm instead of 18mm locating spigot.

VW

Application	Image	Part No.	PCD	Bolt Dia	OD	Bore	Width
VW AWD	Steel Shroud 	GAV-01-003	105mm	10mm 6 Holes			26mm C/Sunk



www.hardyspicer.com.au

Document No:	HSDSCAT
Issue:	15
Issue Date:	03/11/14

This catalogue is the copyright
of Hardy Spicer

PROPELLER SHAFT CV JOINTS

BMW

Application	Image	Part No.	Type	Spline	OD	PCD	Boot Kit
BMW		CV-874	Plunging	26.46# x 24spl 24mm Wide Inner Race	94mm	80mm	CV-852
BMW (10mm Bolt Holes) OEM # 26 11 1229 075		CV-885 Joint Only	Plunging	28.00# x 25spl 32mm Wide Inner Race	99.5mm	86mm	CV-853 [^]

[^] Bolts holes need to be drilled out to 10mm

CHINESE BUSES (Various)

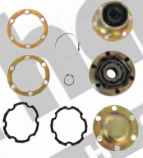
Application	Image	Part No.	Stub	Spline	OD	PCD	Boot Kit
CHINESE BUS FAN DRIVESHAFT		CV-5052KIT Plunging	NL-56-5052	19spl 25.9mm Wide Inner Race	86mm 30mm Wide	74mm	NSS

FORD

Application	Image	Part No.	Stub	Spline	OD	PCD	Boot Kit
BA FALCON 6 cyl (non turbo) BA FALCON V8, XR6 & XR8 WITH CENTRE U/JOINT EXPLORER 97 ON FRONT SHAFT ONLY <i>If IFA markings on joint with 33 spline count, contact Hardy Spicer for replacement options</i>	 Rear	CV-860 Plunging	FD-56-2557	26.90# x 32spl	99.4mm	86mm	CV-877
BA FALCON V8, XR6 & XR8 FITTED WITH CENTRE CV	 Rear	CV-861 Fixed	FD-56-3300	28.00# x 25spl	100mm	86mm	CV-866
BA FALCON V8, XR6 & XR8 FITTED WITH CENTRE CV WITH GKN MARKINGS	 Middle	CV-862* Plunging	FD-56-2918	31.00# x 28spl 29mm Wide Inner Race	108mm	94mm	CV-863
BF FALCON (Some) FG V8, XR6T (Mostly Utes) FITTED WITH CENTRE CV WITH IFA MARKINGS	 Middle	CV-898 Plunging	FD-56-3906	31.00# x 28spl 32mm Wide Inner Race	108mm	94mm	CV-863
FG FPV S/CHARGED V8 (With GKN markings) BF, FG FALCON (REPLACEMENT ONLY DOES NOT FIT OEM STUB) <i>If IFA markings on joint with wider inner race, contact Hardy Spicer for replacement options</i>		CV-882 Plunging	FD-56-9579	31.00# x 28spl Recessed Rear Cap	108mm	94mm	10056153 Lardge ID Boot Only
COURIER V6 WELD JOINT ASSY	 90x4 Male Spigot	CV-876 Fixed		35 spl	124mm	107mm 6 Holes (10.2mm)	

www.hardyspicer.com.au

Document No:	HSDSCAT
Issue:	15
Issue Date:	03/11/14

Note: All spline dimensions are a nominal size.
* Support plates to suit CV-862 - Part No. **806-R25**

FORD cont.

Application	Image	Part No.	Stub	Spline	OD	PCD	Boot Kit
COURIER V6 CV JOINT & BOOT ONLY	90x4 Male Spigot 	CV-881 Fixed		35 spl	124mm	107mm 6 Holes (10.2mm)	
ESCAPE WELD JOINT ASSY		CV-875 Plunging	inner race	28.90# x 26spl 42mm wide outer race 39mm wide	100mm	86mm 6 Holes (8.25mm)	
EXPLORER 98-05 WELD JOINT ASSY FRONT OF REAR SHAFT	104mm Male Spigot 	CV-873 Plunging		29.00# x 26spl 35.5mm wide	107mm	91mm	
EXPLORER 98-05 FRONT OF REAR SHAFT	104mm Male Spigot 	CV-872 Plunging		29.00# x 26spl 35.5mm wide	107mm	91mm	
RANGER PX 4WD FRONT OF FRONT SHAFT		CV-861 Fixed	FD-56-3300	28.00# x 25spl	100mm	86mm	CV-866
RANGER PX 4WD REAR OF FRONT SHAFT		CV-871 Long Plunging 68mm		28.00# x 25spl	100mm 41.8mm Over Caps	86mm	CVK-872 Use Orig. Rear Grease Cover
TERRITORY	Rear 	CV-868 Plunging 50mm		28.00# x 25spl	100mm	86mm	CVK-869
TERRITORY COMPLETE ASSEMBLY INCLUDING STUB	Rear 	CV-870 Plunging 50mm		28.00# x 25spl	100mm	86mm	CVK-869
TERRITORY AWD FRONT SHAFT		CV-861 Fixed	FD-56-3300	28.00# x 25spl	100mm	86mm	CV-866
TERRITORY AWD FRONT SHAFT		CV-874 Plunging		26.46# x 24spl 24mm wide Inner race	94mm	80mm	CV-852

Note: All spline dimensions are a nominal size.

www.hardyspicer.com.au

Document No:	HSDSCAT
Issue:	15
Issue Date:	03/11/14

HOLDEN

Application	Image	Part No.	Stub	Spline	OD	PCD	Boot Kit
CAPTIVA 4WD	Rear - Rear Shaft 	CV-871 Long Plunging 68mm		28.00# x 25spl	100mm 41.8mm Over Caps	86mm	CVK-872
COMMODORE 6CYL VB - VL (June 1988)	Middle 	CV-856 Plunging		26.46# x 24spl 29mm wide	94mm Inner race	80mm	CV-852
COMMODORE 8 CYL ALL COMMODORE 6CYL VN on	Middle 	CV-855A Plunging		27.50# x 25spl	100mm	86mm	CV-853
CREWMAN	Middle 	CV-861 Fixed	HO-56-3429	28.00# x 25spl	100mm	86mm	CV-866
CREWMAN	Rear 	CV-865 Long Plunging	HO-56-3434	28.00# x 25spl	108mm	94mm	CV-867
HSV VY AVALANCHE ADVENTRA, CROSS 6/8 4WD COMMODORE (ALSO SUITS PLUNGING JOINT ON FRONT SHAFT)	Middle - Rear Shaft 	CV-874 Plunging		26.46# x 24spl 24mm wide	94mm Inner race	80mm	CV-852
HSV VY AVALANCHE ADVENTRA, CROSS 6/8 4WD COMMODORE (ALSO SUITS FIXED JOINT ON FRONT SHAFT)	Rear - Rear Shaft 	CV-861 Fixed		28.00# x 25spl	100mm	86mm	CV-866

Support plates for CV-855A - 806-R16

HONDA

Application	Image	Part No.	Type	Spline	OD	PCD	Boot Kit
CRV	CENTRE CV BOOT 	CV-888					CRIMP TYPE

www.hardyspicer.com.au

Document No:	HSDSCAT
Issue:	15
Issue Date:	03/11/14

Note: All spline dimensions are a nominal size.

HYUNDAI

Application	Image	Part No.	Stub	Spline	OD	PCD	Boot Kit
TERRACAN 2004-2007 FRONT SHAFT		CV-874 Plunging		26.46# x 24spl 24mm wide Inner race	94mm	80mm	CV-852



JEEP

Application	Image	Part No.	Type	Spline	OD	PCD	Boot Kit
JEEP GRAND CHEROKEE 93-98	Front Shaft Rear Joint 	CV-868	Plunging 50mm	28.00# x 25spl	100mm 34mm Over Caps	86mm	CVK-869
JEEP COMPLETE ASSEMBLY INCLUDING STUB GRAND CHEROKEE 93-98	Front Shaft Rear Assy 	CV-870	Plunging 50mm	28.00# x 25spl	100mm	86mm	CVK-869
JEEP GRAND CHEROKEE 4.0L 1999-2001 4.7L 1999-2004	Front Shaft Front Joint 	CV-871	Long Plunging 68mm	28.00# x 25spl	100mm 41.8mm Over Caps	86mm	CVK-872
JEEP GRAND CHEROKEE 4.0L, 4.7L 1999-2004	Front Shaft Rear Joint 	CV-861	Fixed	28.00# x 25spl	100mm	86mm	CV-866
JEEP GRAND CHEROKEE 1999-2004	Front Shaft Rear Joint 	CV-865	Long Plunging	28.00# x 25spl	108mm	94mm	CV-867
JEEP JK WRANGLER 2007-2013		CV-896 #	NON PLUNGING 8 BALL	35spl	100mm		CVK-901 #
JEEP COMMANDER 2006	Front Shaft Transfer Case End 	CVJ.CHT3 #	Plunging	30spl	108mm 37mm Wide		



www.hardyspicer.com.au



Document No:	HSDSCAT
Issue:	15
Issue Date:	03/11/14

INDENT ITEM ONLY

KIA							
Application	Image	Part No.	Type	Spline	OD	PCD	Boot Kit
SPORTAGE 4WD KM 2.7L V6 AUTO	 Rear	CV-868	Plunging 50mm	28.00# x 25spl	100mm	86mm	CVK-869
SPORTAGE 4WD KM 2.7L V6 AUTO COMPLETE ASSEMBLY INCLUDING STUB	 Rear	CV-870	Plunging 50mm	28.00# x 25spl	100mm	86mm	CVK-869

LANDROVER							
Application	Image	Part No.	Type	Spline	OD	PCD	Boot Kit
FREELANDER PROPSHAFT CV		CV-886	Tripod				CV-887

MAZDA							
Application	Image	Part No.	Type	Spline	OD	PCD	Boot Kit
BRAVO V6 WELD JOINT ASSY	 90x4 Male Spigot	CV-876	Fixed	35spl	124mm	107mm 6 Holes (10.2mm)	
BRAVO V6 JOINT & BOOT ONLY	 90x4 Male Spigot	CV-881	Fixed	35spl	124mm	107mm 6 Holes (10.2mm)	
TRIBUTE WELD JOINT ASSY	 Rear of Rear Shaft	CV-875	Plunging	28.90# x 26spl 42mm wide outer race 39mm wide inner race	100mm	86mm 6 Holes (8.25mm)	



MITSUBISHI							
Application	Image	Part No.	Type	Spline	OD	PCD	Boot Kit
PAJERO TRITON WELD JOINT ASSY	 90x4 Male Spigot	CV-876	Fixed	35spl	124mm	107mm 6 Holes (10.2mm)	
PAJERO TRITON JOINT & BOOT ONLY	 90x4 Male Spigot	CV-881	Fixed	35spl	124mm	107mm 6 Holes (10.2mm)	
OUTLANDER (Rear) CHALLENGER (Front some)	 78.72 x 4.5 Spigot	CV-895	Fixed	30spl	116.5mm	98.6mm 3 Holes (10.3mm)	CRIMP TYPE

www.hardyspicer.com.au

Document No:	HSDSCAT
Issue:	15
Issue Date:	03/11/14

Note: All spline dimensions are a nominal size.

NISSAN

Application	Image	Part No.	Type	Spline	OD	PCD	Boot Kit
SKYLINE R31 1986-1988	 Middle	CV-856	Plunging	26.46# x 24spl	94mm	80mm	CV-852
SKYLINE R31 6/88-1991	 Middle	CV-855A	Plunging	27.50# x 25spl	100mm	86mm	CV-853

PORSCHE

Application	Image	Part No.	Type	Spline	OD	PCD	Boot Kit
CAYENNE REAR PROPSHAFT	 Centre		Crimp		95.7mm	N/A	CVK-880

TOYOTA

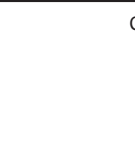
Application	Image	Part No.	Type	Spline	OD	PCD	Boot Kit
RAV 4 AWD ACA33 11/2005 - 11/2012	 Centre		Crimp			N/A	CVK-910

www.hardyspicer.com.au

Document No:	HSDSCAT
Issue:	15
Issue Date:	03/11/14

VW

Application	Image	Part No.	Type	Spline	OD	PCD	Boot Kit
TOUAREG REAR PROPSHAFT	 Centre		Crimp		95.7mm	N/A	CVK-880

VOLVO

Application	Image	Part No.	Type	Spline	OD	PCD	Boot Kit
		CV-878	Plunging	20.03# x 24spl 23.4mm wide Inner Race	78mm	65mm	CV-879
850 (Some) XC70 (Some) XC90 (Some) WITH GKN MARKINGS		NL-7-05	Plunging	20spl 22mm wide Inner Race	86mm 21mm Wide 83.5mm x 6mm Step one side	74mm	NL-5-05 NL-20-05 (End Cap)
850 (Some) XC70 (Some) XC90 (Some) WITH NTN MARKINGS		CVJ.706	Plunging	19spl 22mm wide Inner Race	86mm 21mm Wide 83.5mm x 6mm Step one side	74mm	
S70 / V70	 Some	CV-874	Plunging	26.46# x 24spl 24mm wide Inner Race	94mm	80mm	CV-852

CV GREASE

Synthetic Heavy Duty CV Grease

Part Number	Size
GCV-004	450 grams



Note: All spline dimensions are a nominal size.

www.hardyspicer.com.au

Document No:	HSDSCAT
Issue:	15
Issue Date:	03/11/14

This catalogue is the copyright
of Hardy Spicer

NOTES

hardy spicer
• HOSE • FITTINGS • DRIVESHAFTS

hardy spicer
• HOSE • FITTINGS • DRIVESHAFTS

www.hardyspicer.com.au

Document No:	HSDSCAT
Issue:	15
Issue Date:	03/11/14

This catalogue is the copyright of Hardy Spicer